

INSTRUCTION MANUAL

Metal cutter

4131

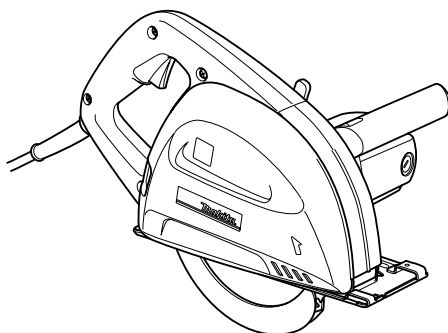

005343



IMPORTANT: Read Before Using.

ENGLISH (Original instructions)

SPECIFICATIONS

Model	4131
Blade diameter	185 mm
Max. cutting capacity	63 mm
No load speed (min ⁻¹)	3,500
Overall length	358 mm
Net weight	5.1 kg
Safety class	II/II

- Due to our continuing program of research and development, the specifications herein are subject to change without notice.
- Specifications may differ from country to country.
- Weight according to EPTA-Procedure 01/2003

END209-4

Symbols

The following show the symbols used for the equipment. Be sure that you understand their meaning before use.



- Read instruction manual.



- DOUBLE INSULATION



- Pay attention! It may become too hot.



- Only for EU countries
Do not dispose of electric equipment together with household waste material!

In observance of European Directive 2012/19/EU on waste electric and electronic equipment and its implementation in accordance with national law, electric equipment that have reached the end of their life must be collected separately and returned to an environmentally compatible recycling facility.

ENE022-1

Intended use

The tool is intended for cutting in mild steel.

ENF002-2

Power supply

The tool should be connected only to a power supply of the same voltage as indicated on the nameplate, and can only be operated on single-phase AC supply. They are double-insulated and can, therefore, also be used from sockets without earth wire.

ENG905-1

Noise

The typical A-weighted noise level determined according to EN60745:

Sound pressure level (L_{pA}) : 89 dB(A)
Sound power level (L_{WA}) : 100 dB(A)
Uncertainty (K) : 3 dB(A)

Wear ear protection

ENG900-1

Vibration

The vibration total value (tri-axial vector sum) determined according to EN60745:

Work mode : cutting metal
Vibration emission ($a_{h,M}$) : 2.5 m/s² or less
Uncertainty (K) : 1.5 m/s²

ENG901-1

- The declared vibration emission value has been measured in accordance with the standard test method and may be used for comparing one tool with another.
- The declared vibration emission value may also be used in a preliminary assessment of exposure.

⚠WARNING:

- The vibration emission during actual use of the power tool can differ from the declared emission value depending on the ways in which the tool is used.
- Be sure to identify safety measures to protect the operator that are based on an estimation of exposure in the actual conditions of use (taking account of all parts of the operating cycle such as the times when the tool is switched off and when it is running idle in addition to the trigger time).

ENH101-16

For European countries only

EC Declaration of Conformity

We Makita Corporation as the responsible manufacturer declare that the following Makita machine(s):

Designation of Machine:

Metal cutter

Model No./ Type: 4131

are of series production and

Conforms to the following European Directives:

2006/42/EC

And are manufactured in accordance with the following standards or standardised documents:

EN60745

The technical documentation is kept by:

Makita International Europe Ltd.
Technical Department,
Michigan Drive, Tongwell,
Milton Keynes, Bucks MK15 8JD, England

30.1.2009



000230

Tomoyasu Kato
Director
Makita Corporation
3-11-8, Sumiyoshi-cho,
Anjo, Aichi, 446-8502, JAPAN

GEA005-3

General Power Tool Safety Warnings

⚠ WARNING Read all safety warnings and all instructions. Failure to follow the warnings and instructions may result in electric shock, fire and/or serious injury.

Save all warnings and instructions for future reference.

The term "power tool" in the warnings refers to your mains-operated (corded) power tool or battery-operated (cordless) power tool.

Work area safety

1. **Keep work area clean and well lit.** Cluttered or dark areas invite accidents.
2. **Do not operate power tools in explosive atmospheres, such as in the presence of flammable liquids, gases or dust.** Power tools create sparks which may ignite the dust or fumes.
3. **Keep children and bystanders away while operating a power tool.** Distractions can cause you to lose control.

Electrical safety

4. **Power tool plugs must match the outlet. Never modify the plug in any way. Do not use any adapter plugs with earthed (grounded) power tools.** Unmodified plugs and matching outlets will reduce risk of electric shock.
5. **Avoid body contact with earthed or grounded surfaces such as pipes, radiators, ranges and refrigerators.** There is an increased risk of

6. **Do not expose power tools to rain or wet conditions.** Water entering a power tool will increase the risk of electric shock.
7. **Do not abuse the cord. Never use the cord for carrying, pulling or unplugging the power tool. Keep cord away from heat, oil, sharp edges or moving parts.** Damaged or entangled cords increase the risk of electric shock.
8. **When operating a power tool outdoors, use an extension cord suitable for outdoor use.** Use of a cord suitable for outdoor use reduces the risk of electric shock.
9. **If operating a power tool in a damp location is unavoidable, use a residual current device (RCD) protected supply.** Use of an RCD reduces the risk of electric shock.
10. **Use of power supply via a RCD with a rated residual current of 30mA or less is always recommended.**

Personal safety

11. **Stay alert, watch what you are doing and use common sense when operating a power tool. Do not use a power tool while you are tired or under the influence of drugs, alcohol or medication.** A moment of inattention while operating power tools may result in serious personal injury.
12. **Use personal protective equipment. Always wear eye protection.** Protective equipment such as dust mask, non-skid safety shoes, hard hat, or hearing protection used for appropriate conditions will reduce personal injuries.
13. **Prevent unintentional starting. Ensure the switch is in the off-position before connecting to power source and/or battery pack, picking up or carrying the tool.** Carrying power tools with your finger on the switch or energising power tools that have the switch on invites accidents.
14. **Remove any adjusting key or wrench before turning the power tool on.** A wrench or a key left attached to a rotating part of the power tool may result in personal injury.
15. **Do not overreach. Keep proper footing and balance at all times.** This enables better control of the power tool in unexpected situations.
16. **Dress properly. Do not wear loose clothing or jewellery. Keep your hair, clothing, and gloves away from moving parts.** Loose clothes, jewellery or long hair can be caught in moving parts.
17. **If devices are provided for the connection of dust extraction and collection facilities, ensure these are connected and properly used.** Use of dust collection can reduce dust-related hazards.

Power tool use and care

18. **Do not force the power tool. Use the correct power tool for your application.** The correct power tool will do the job better and safer at the rate for which it was designed.
19. **Do not use the power tool if the switch does not turn it on and off.** Any power tool that cannot be controlled with the switch is dangerous and must be repaired.
20. **Disconnect the plug from the power source and/or the battery pack from the power tool before making any adjustments, changing accessories, or storing power tools.** Such preventive safety measures reduce the risk of starting the power tool accidentally.
21. **Store idle power tools out of the reach of children and do not allow persons unfamiliar with the power tool or these instructions to operate the power tool.** Power tools are dangerous in the hands of untrained users.
22. **Maintain power tools. Check for misalignment or binding of moving parts, breakage of parts and any other condition that may affect the power tool's operation. If damaged, have the power tool repaired before use.** Many accidents are caused by poorly maintained power tools.
23. **Keep cutting tools sharp and clean.** Properly maintained cutting tools with sharp cutting edges are less likely to bind and are easier to control.
24. **Use the power tool, accessories and tool bits etc. in accordance with these instructions, taking into account the working conditions and the work to be performed.** Use of the power tool for operations different from those intended could result in a hazardous situation.

Service

25. **Have your power tool serviced by a qualified repair person using only identical replacement parts.** This will ensure that the safety of the power tool is maintained.
26. **Follow instruction for lubricating and changing accessories.**
27. **Keep handles dry, clean and free from oil and grease.**

GEB030-4

METAL CUTTER SAFETY WARNINGS

Cutting procedures

1. **⚠ DANGER: Keep hands away from cutting area and the blade. Keep your second hand on auxiliary handle, or motor housing.** If both hands are holding the saw, they cannot be cut by the blade.
 2. **Do not reach underneath the workpiece.** The guard cannot protect you from the blade below the workpiece.
 3. **Adjust the cutting depth to the thickness of the workpiece.** Less than a full tooth of the blade teeth should be visible below the workpiece.
 4. **Never hold piece being cut in your hands or across your leg. Secure the workpiece to a stable platform.** It is important to support the work properly to minimize body exposure, blade binding, or loss of control.
 5. **Hold the power tool by insulated gripping surfaces only, when performing an operation where the cutting tool may contact hidden wiring or its own cord.** Contact with a "live" wire will also make exposed metal parts of the power tool "live" and could give the operator an electric shock.
 6. **When ripping, always use a rip fence or straight edge guide.** This improves the accuracy of cut and reduces the chance of blade binding.
 7. **Always use blades with correct size and shape (diamond versus round) of arbour holes.** Blades that do not match the mounting hardware of the saw will run eccentrically, causing loss of control.
 8. **Never use damaged or incorrect blade washers or bolt.** The blade washers and bolt were specially designed for your saw, for optimum performance and safety of operation.
- Kickback causes and related warnings**
- kickback is a sudden reaction to a pinched, bound or misaligned saw blade, causing an uncontrolled saw to lift up and out of the workpiece toward the operator;
 - when the blade is pinched or bound tightly by the kerf closing down, the blade stalls and the motor reaction drives the unit rapidly back toward the operator;
 - if the blade becomes twisted or misaligned in the cut, the teeth at the back edge of the blade can dig into the top surface of the workpiece causing the blade to climb out of the kerf and jump back toward the operator.
- Kickback is the result of saw misuse and/or incorrect operating procedures or conditions and can be avoided by taking proper precautions as given below.
9. **Maintain a firm grip with both hands on the saw and position your arms to resist kickback forces. Position your body to either side of the blade, but not in line with the blade.** Kickback could cause the saw to jump backwards, but kickback forces can be controlled by the operator, if proper precautions are taken.

10. **When blade is binding, or when interrupting a cut for any reason, release the trigger and hold the saw motionless in the material until the blade comes to a complete stop. Never attempt to remove the saw from the work or pull the saw backward while the blade is in motion or kickback may occur.** Investigate and take corrective actions to eliminate the cause of blade binding.
11. **When restarting a saw in the workpiece, centre the saw blade in the kerf and check that saw teeth are not engaged into the material.** If saw blade is binding, it may walk up or kickback from the workpiece as the saw is restarted.
12. **Support large panels to minimise the risk of blade pinching and kickback.** Large panels tend to sag under their own weight. Supports must be placed under the panel on both sides, near the line of cut and near the edge of the panel.
13. **Do not use dull or damaged blades.** Unsharpened or improperly set blades produce narrow kerf causing excessive friction, blade binding and kickback.
14. **Blade depth and bevel adjusting locking levers must be tight and secure before making cut.** If blade adjustment shifts while cutting, it may cause binding and kickback.
15. **Use extra caution when sawing into existing walls or other blind areas.** The protruding blade may cut objects that can cause kickback.
19. **Always observe that the lower guard is covering the blade before placing saw down on bench or floor.** An unprotected, coasting blade will cause the saw to walk backwards, cutting whatever is in its path. Be aware of the time it takes for the blade to stop after switch is released.
20. **To check lower guard, open lower guard by hand, then release and watch guard closure. Also check to see that retracting handle does not touch tool housing.** Leaving blade exposed is VERY DANGEROUS and can lead to serious personal injury.

Additional safety warnings

Lower guard function

21. **Do not stop the blades by lateral pressure on the blade.**
22. **DANGER:**
Do not attempt to remove cut material when blade is moving.
CAUTION: Blades coast after turn off.
23. **Place the wider portion of the tool base on that part of the workpiece which is solidly supported, not on the section that will fall off when the cut is made.**
24. **Never attempt to make a cut with the tool held upside down in a vise. This is extremely dangerous and can lead to serious accidents.**
25. **Wear safety goggles and hearing protection during operation.**
26. **Always use blades recommended in this manual. Do not use any abrasive wheels.**
16. **Check lower guard for proper closing before each use. Do not operate the saw if lower guard does not move freely and close instantly. Never clamp or tie the lower guard into the open position.** If saw is accidentally dropped, lower guard may be bent. Raise the lower guard with the retracting handle and make sure it moves freely and does not touch the blade or any other part, in all angles and depths of cut.
17. **Check the operation of the lower guard spring. If the guard and the spring are not operating properly, they must be serviced before use.** Lower guard may operate sluggishly due to damaged parts, gummy deposits, or a build-up of debris.
18. **Lower guard may be retracted manually only for special cuts such as "plunge cuts" and "compound cuts". Raise lower guard by retracting handle and as soon as blade enters the material, the lower guard must be released.** For all other sawing, the lower guard should operate automatically.

SAVE THESE INSTRUCTIONS.

WARNING:

DO NOT let comfort or familiarity with product (gained from repeated use) replace strict adherence to safety rules for the subject product. **MISUSE** or failure to follow the safety rules stated in this instruction manual may cause serious personal injury.

FUNCTIONAL DESCRIPTION

⚠CAUTION:

- Always be sure that the tool is switched off and unplugged before adjusting or checking function on the tool.

Adjusting the depth of cut

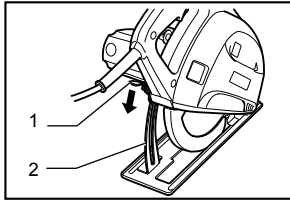

1. Lever
2. Depth guide

005344

Loosen the lever on the depth guide and move the base up or down. At the desired depth of cut, secure the base by tightening the lever.

⚠CAUTION:

- After adjusting the depth of cut, always tighten the lever securely.

Sighting

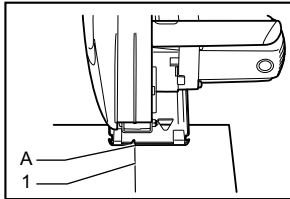

1. Cutting line

005345

When cutting, align the A position on the front of the base with your cutting line on the workpiece.

Switch action

⚠CAUTION:

- Before plugging in the tool, always check to see that the switch trigger actuates properly and returns to the "OFF" position when released.

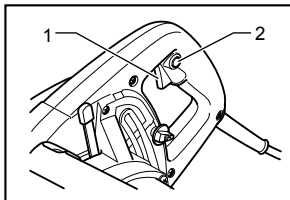

1. Switch trigger
2. Lock-off button

005346

To prevent the switch trigger from being accidentally pulled, a lock-off button is provided.

To start the tool, push in the lock-off button and pull the switch trigger. Release the switch trigger to stop.

ASSEMBLY

⚠CAUTION:

- Always be sure that the tool is switched off and unplugged before carrying out any work on the tool.

Installing or removing saw blade

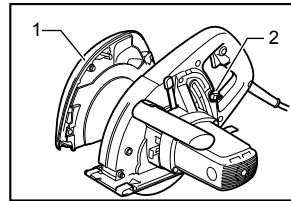

1. Dust cover
2. Knob

005347

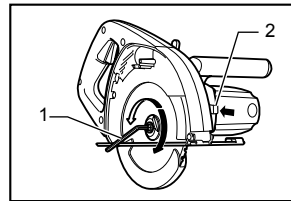

1. Hex wrench
2. Shaft lock

005348

⚠CAUTION:

- Use only the Makita wrench provided to install or remove the blade. Failure to do so may result in overtightening or insufficient tightening of the hex bolt. This could cause serious injury to the operator.
- Do not touch the blade with your bare hand immediately after cutting, it may be extremely hot and could burn your skin. Put on pair of gloves when removing a hot blade.

To remove the blade, first push and turn the knob which secures the dust cover clockwise to the  symbol and remove the dust cover. Press the shaft lock so that the blade cannot revolve and use the hex wrench to loosen the hex bolt counterclockwise. Then remove the outer flange and blade.

To install the blade, follow the removal procedure in reverse. Always install the blade so that the arrow on the blade points in the same direction as the arrow on the blade case.

BE SURE TO TIGHTEN THE HEX BOLT SECURELY.

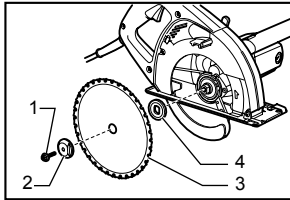

1. Hex socket head bolt
2. Outer flange
3. Carbide-tipped saw blade
4. Inner flange

005349

After installing the blade, replace the dust cover. Slide the dust cover carefully so that the slot of its front fits the rib of the blade case. Make sure the dust cover fits properly then push and turn the knob counterclockwise to the ● symbol.

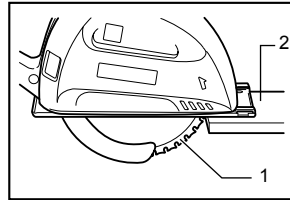

1. Carbide-tipped saw blade
2. Workpiece

005352

Hold the tool firmly with both hand. Set the base plate on the workpiece to be cut without the blade making any contact. Then turn the tool on and wait until the blade attains full speed. Move the tool forward over the workpiece surface, keeping it flat and advancing smoothly until the cutting is completed. Keep your cutting line straight and your speed of advance uniform. The sight window in the base makes it easy to check the distance between the front edge of the saw blade and the workpiece whenever the blade is set to the maximum depth of cut.

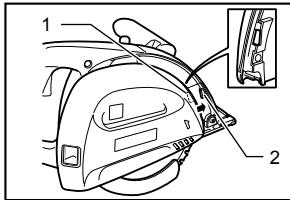

1. Slot
2. Rib

005350

Rip fence (guide rule) (Accessory)

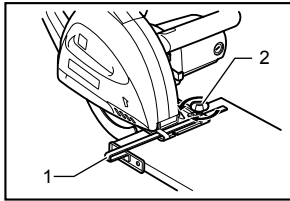

1. Rip fence (Guide rule)
2. Screw

005351

The handy rip fence (guide rule) allows you to do extra-accurate straight cuts. Simply slide the rip fence up snugly against the side of the workpiece and secure it in position with the clamp screw on the front of the base. It also makes repeated cuts of uniform width possible.

OPERATION

⚠ CAUTION:

- Never twist or force the tool in the cut. This may cause motor overload and/or a dangerous kickback, resulting in serious injury to the operator.

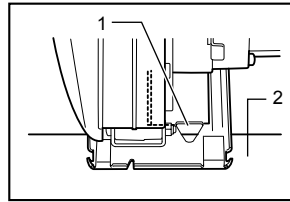

1. Sight window
2. Workpiece

005353

NOTE:

- When making a miter cuts etc., sometimes the lower guard does not move easily. At that time, use the retracting lever to raise the lower guard for starting cut and as soon as blade enters the material, release the retracting lever.

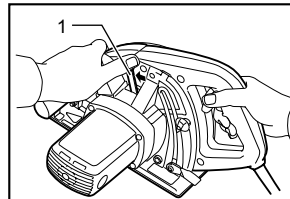

1. Retracting lever

005354

⚠ CAUTION:

- Do not use a deformed or cracked blade. Replace it with a new one.
- Do not stack materials when cutting them.
- Do not cut hardened steel, stainless steel, aluminum, wood, plastics, concrete, tile, etc. **Cut only mild steel.**

- Do not touch the saw blade, workpiece or cutting chips with your bare hand immediately after cutting, they may be extremely hot and could burn your skin.
- Always use the carbide-tipped saw blades appropriate for your job.** The use of inappropriate saw blades may cause a poor cutting performance and/or present a risk of personal injury.

Chip disposal

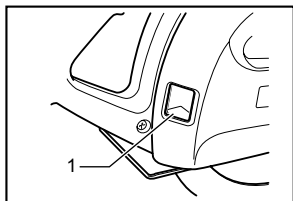

1. Sight window

005355

⚠CAUTION:

- Always be sure that the tool is switched off and unplugged before removing or installing the dust cover.
- The dust cover may become hot due to hot chips. Do not touch the cutting chips or dust cover with your bare hand.

When the cutting chips are visible through the sight window, dispose of them.

Push and turn the knob clockwise to the  symbol and remove the dust cover. Dispose of the cutting chips accumulated inside the dust cover.

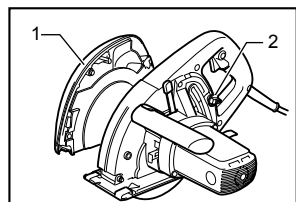

1. Dust cover
2. Knob

005347

⚠CAUTION:

- Do not turn the tool upside down. The cutting chips accumulated inside the dust cover may fall out of the dust cover.
- Handle the dust cover carefully so that it will not be deformed or damaged.

MAINTENANCE

⚠CAUTION:

- Always be sure that the tool is switched off and unplugged before attempting to perform inspection or maintenance.
- Never use gasoline, benzene, thinner, alcohol or the like. Discoloration, deformation or cracks may result.

Inspecting saw blade

- Check the blade carefully for cracks or damage before and after each use. Replace a cracked or damaged blade immediately.
- Continuing to use a dull blade may cause a dangerous kickback and/or motor overload. Replace with a new blade as soon as it no longer cuts effectively.
- Carbide-tipped saw blades for metal cutter cannot be re-sharpened.**

Replacing carbon brushes

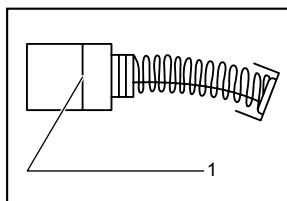

1. Limit mark

001145

Remove and check the carbon brushes regularly. Replace when they wear down to the limit mark. Keep the carbon brushes clean and free to slip in the holders. Both carbon brushes should be replaced at the same time. Use only identical carbon brushes.

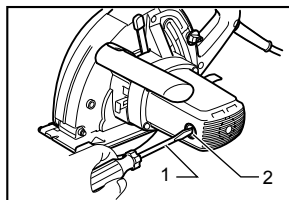

1. Screwdriver
2. Brush holder cap

005356

Use a screwdriver to remove the brush holder caps. Take out the worn carbon brushes, insert the new ones and secure the brush holder caps.

To maintain product SAFETY and RELIABILITY, repairs, any other maintenance or adjustment should be performed by Makita Authorized Service Centers, always using Makita replacement parts.

OPTIONAL ACCESSORIES

⚠CAUTION:

- These accessories or attachments are recommended for use with your Makita tool specified in this manual. The use of any other accessories or attachments might present a risk of injury to persons. Only use accessory or attachment for its stated purpose.

If you need any assistance for more details regarding these accessories, ask your local Makita Service Center.

- Rip fence (Guide rule)
- Safety goggle
- Recommended Carbide-tipped saw blades & workpiece ranges

NOTE:

- Some items in the list may be included in the tool package as standard accessories. They may differ from country to country.

Carbide-Tipped Metal Blades for Many Applications

Size(mm)	Applications													
	METAL SHEET		C-STUD		ANGLE-STUD		METAL STUD		REBAR	PIPE			CORRUGATED SHEET	
	t=1.5	t=3.0	50X100 t=1.6	45X90 t=3.2	50X50 t=4	50X50 t=6	t=0.56 25Ga	t=1.6 16Ga	∅20	50X100 t=3.2	∅25 t=1.2	∅60 t=3.8	t=0-0.9	t=1.0-2.0
185X36T	X	⊙	X	⊙	⊙	⊙	⊙	X	⊙	⊙	△	⊙	X	X
185X38T	△	○	△	○	○	⊙	⊙	△	○	○	⊙	○	X	X
185X48T	○	○	○	○	△	○	⊙	⊙	△	○	⊙	△	X	△
185X70T	⊙	△	X	X	X	X	△	X	X	X	X	X	⊙	△

⊙ Excellent ○ Good △ Fair X Not Applicable

005705

⚠CAUTION:

- Always use carbide-tipped saw blades appropriate for your job. Do not cut aluminum, wood, plastics, concrete, tiles, etc.
- Carbide-tipped saw blades for metal cutting saw are not to be re-sharpened.

Makita Corporation
Anjo, Aichi, Japan

884543H224

www.makita.com