

INSTRUCTION MANUAL

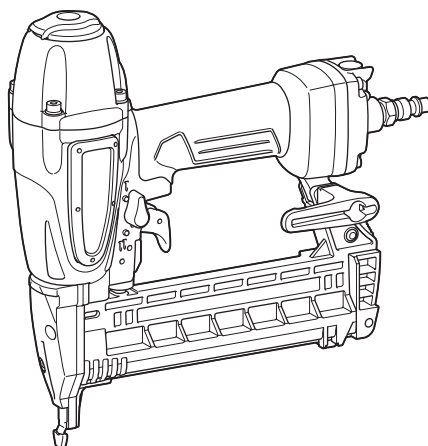

Narrow Crown Stapler

AT638A



Read before use.

SPECIFICATIONS

Model:	AT638A
Air pressure	0.49 - 0.83 MPa (4.9 - 8.3 bar)
Staple length	13 mm - 38 mm
Staple capacity	100 pcs.
Minimum hose diameter	6.5 mm
Pneumatic tool oil	ISO VG32 or equivalent
Dimensions (L x W x H)	230 mm x 75 mm x 251 mm
Net weight	1.2 kg

- Due to our continuing program of research and development, the specifications herein are subject to change without notice.
- Specifications may differ from country to country.
- Weight according to EPTA-Procedure 01/2003

Symbols

The following show the symbols used for the equipment. Be sure that you understand their meaning before use.



Read instruction manual.



Wear safety glasses.



Do not use on scaffoldings, ladders.

Intended use

The tool is intended for fastening on interior work and furniture work.

SAFETY WARNINGS

Pneumatic nailer/stapler safety warnings

⚠ WARNING: WARNING Read all safety warnings and all instructions. Failure to follow the warnings and instructions may result in serious injury, electric shock and/or fire.

Save all warnings and instructions for future reference.

For personal safety and proper operation and maintenance of the tool, read this instruction manual before using the tool.

General safety

1. Do not permit those un instructed to use the tool.
2. No horseplay. Respect the tool as a working implement.
3. Do not operate when under the influence of alcohol, drugs or the like.
4. Never alter the tool.

Personal protective equipments

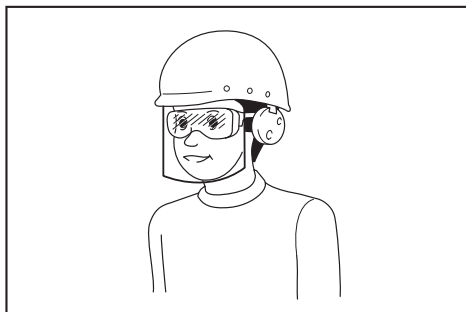

1. Always wear safety glasses to protect your eyes from dust or fastener injury.
⚠ WARNING: It is an employer's responsibility to enforce the use of safety eye protection equipment by the tool operators and by other persons in the immediate working area.
For Australia and New Zealand only
Always wear safety glasses and face shield to protect your eyes from dust or fastener injury. The safety glasses and the face shield should conform with the requirements of AS/NZS 1336.
2. Wear hearing protection to protect your ears against exhaust noise and head protection. Also wear light but not loose clothing. Sleeves should be buttoned or rolled up. No necktie should be worn.

Work area safety

1. Keep work area clean and well lit. Cluttered or dark areas invite accidents.
2. Do not operate the tool in explosive atmospheres, such as in the presence of flammable liquids, gases or dust. Operating the tool can create sparks which may ignite the dust or fumes.
3. Keep children and bystanders away while operating the tool. Distractions can cause you to lose control.
4. Illuminate the work area sufficiently.
5. There may be local regulations concerning noise which must be complied with by keeping noise levels within prescribed limits. In certain cases, shutters should be used to contain noise.

Safety devices

1. **Make sure all safety systems are in working order before operation.** The tool must not operate if only the trigger is pulled or if only the contact arm is pressed against the wood. It must work only when both actions are performed. Test for possible faulty operation with fasteners unloaded and the pusher in fully pulled position.
2. **Do not play with the contact element: it prevents accidental discharge, so it must be kept on and not removed.** Securing the trigger in the ON position is also very dangerous. Never attempt to fasten the trigger. Do not operate a tool if any portion of the tool operating controls is inoperable, disconnected, altered, or not working properly.
3. **Do not attempt to keep the contact element depressed with tape or wire.** Death or serious injury may occur.
4. **Always check contact element as instructed in this manual.** Fasteners may be driven accidentally if the safety mechanism is not working correctly.

Loading fasteners

1. **Do not load the tool with fasteners when any one of the operating controls is activated.**
2. **Use only fasteners specified in this manual.**
The use of any other fasteners may cause malfunction of the tool.

Power source

1. **Never connect the tool to compressed air line where the air pressure can exceed the suitable air pressure range of the tool, specified in the "SPECIFICATIONS" table, by 10%.** Make sure that the pressure supplied by the compressed air system does not exceed the suitable air pressure range of the tool. Set the air pressure initially to the lower value of the suitable air pressure range.
2. **When using the tool operated by compressed air, particular attention must be paid to avoid exceeding the maximum allowable pressure.**
3. **Operate the tool at the lowest pressure required for the application, in order to prevent unnecessarily high noise levels, increased wear and resulting failures.**
4. **Never use the tool with other than compressed air.** If bottled gas (carbon dioxide, oxygen, nitrogen, hydrogen, air, etc.) or combustible gas (hydrogen, propane, acetylene, etc.) is used as a power source for this tool, the tool will explode and cause serious injury.
5. **Always disconnect the air hose and remove all of the fasteners:**
 - when unattended;
 - before performing any maintenance or repair;
 - before cleaning a jam;
 - before moving the tool to a new location.
6. **Use only pneumatic tool oil specified in this manual.**

Operational safety

1. **Always check the tool for its overall condition and loose screws before operation. Tighten as required.**

2. **Handle the tool carefully, as there is high pressure inside the tool that can be dangerous if a crack is caused by rough handling (dropping or striking). Do not attempt to carve or engrave on the tool.**
3. **Stop the operation immediately if you notice something wrong or out of the ordinary with the tool.** An improperly functioning tool must not be used.
4. **Do not point the ejection port at anyone in the vicinity. Keep hands and feet away from the ejection port area.**
5. **Always assume that the tool contains fasteners.**
6. **Never point the tool toward yourself or anyone whether it contains fasteners or not.**
7. **Do not rush the job or force the tool. Handle the tool carefully.**
8. **Do not activate the tool unless the tool is placed firmly against the workpiece.**
9. **Never hold or carry the tool with a finger on the trigger or hand it to someone in this condition.** Accidental firing can cause serious injury.
10. **Never use fastener driving tools marked with the symbol "Do not use on scaffoldings, ladders" for specific application for example:**
 - when changing one driving location to another involves the use of scaffoldings, stairs, ladders, or ladder alike constructions, e.g. roof laths;
 - closing boxes or crates;
 - fitting transportation safety systems e.g. on vehicles and wagons.
11. **Check walls, ceilings, floors, roofing and the like carefully to avoid possible electrical shock, gas leakage, explosions, etc. caused by striking live wires, conduits or gas pipes.**
12. **Do not use the tool for fastening electrical cables.** It is not designed for electric cable installation and may damage the insulation of electric cables thereby causing electric shock or fire hazards.
13. **Watch your footing and maintain your balance with the tool.** Make sure there is no one below when working in high locations, and secure the air hose to prevent danger if there is sudden jerking or catching.
14. **On rooftops and other high locations, drive fasteners as you move forward.** It is easy to lose your footing if you drive fasteners while inching backward. When driving fasteners against perpendicular surface, work from the top to the bottom. You can perform driving operations with less fatigue by doing so.
15. **A fastener will be bent or the tool can become jammed if you mistakenly drive fastener on top of another fastener or strike a knot in the wood. The fastener may be thrown and hit someone, or the tool itself can react dangerously. Place the fasteners with care.**
16. **Do not leave the loaded tool or the air compressor under pressure for a long time out in the sun. Be sure that dust, sand, chips and foreign matter will not enter the tool in the place where you leave it setting.**

- Never attempt to drive fasteners from both the inside and outside at the same time. Fasteners may rip through and/or fly off, presenting a grave danger.

Service

- Perform cleaning and maintenance right after finishing the job. Keep the tool in tip-top condition. Lubricate moving parts to prevent rusting and minimize friction-related wear. Wipe off all dust from the parts.
- Ask Makita authorized service center for periodical inspection of the tool.
- To maintain product SAFETY and RELIABILITY, maintenance and repairs should be performed by Makita Authorized Service Centers, always using Makita replacement parts.

SAVE THESE INSTRUCTIONS.

⚠ WARNING: DO NOT let comfort or familiarity with product (gained from repeated use) replace strict adherence to safety rules for the subject product. MISUSE or failure to follow the safety rules stated in this instruction manual may cause serious personal injury.

INSTALLATION

Selecting compressor

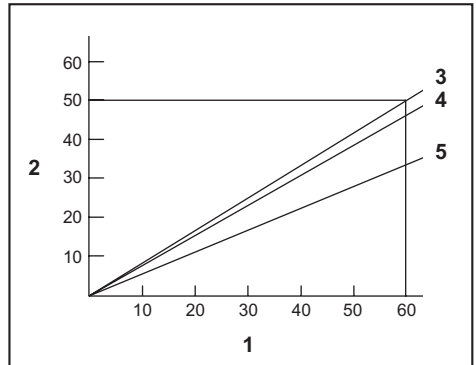

1. Stapling frequency (times/min) 2. Compressor air output per minute (L/min) 3. 0.83 MPa (8.3 bar) 4. 0.66 MPa (6.6 bar) 5. 0.49 MPa (4.9 bar)

The air compressor must comply with the requirements of EN60335-2-34.

Select a compressor that has ample pressure and air output to assure cost-efficient operation. The graph shows the relation between stapling frequency, applicable pressure and compressor air output.

Thus, for example, if stapling takes place at a rate of approximately 60 times per minute at a compression of 0.83 MPa (8.3 bar), a compressor with an air output over 50 liters/minute is required.

Pressure regulators must be used to limit air pressure to the rated pressure of the tool where air supply pressure exceeds the tool's rated pressure. Failure to do so may result in serious injury to tool operator or persons in the vicinity.

Selecting air hose

⚠ CAUTION: Low air output of the compressor, or a long or smaller diameter air hose in relation to the stapling frequency may cause a decrease in the driving capability of the tool.

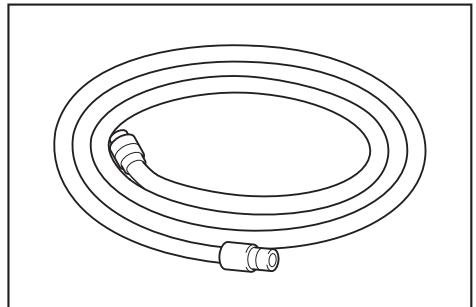

PARTS DESCRIPTION

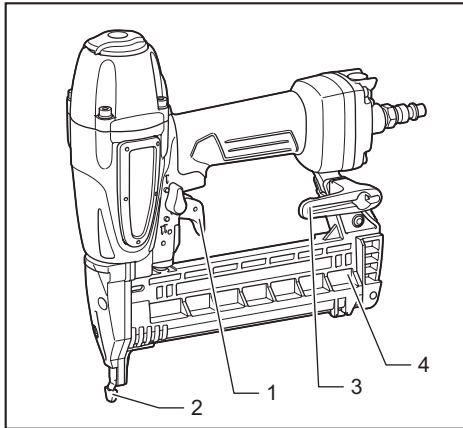

- 1. Trigger 2. Nose adapter (contact element)
3. Hook 4. Magazine

Use an air hose as large and as short as possible to assure continuous, efficient stapling operation.

With an air pressure of 0.49 MPa (4.9 bar), an air hose with an internal diameter of over 6.5 mm and a length of less than 20 m is recommended when the interval between each stapling is 0.5 seconds.

Air supply hoses shall have a minimum working pressure rating of 1.03 MPa (10.3 bar) or 150 percent of the maximum pressure produced in the system whichever is higher.

Lubrication

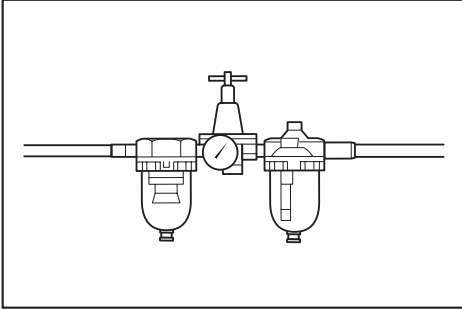

To insure maximum performance, install an air set (oiler, regulator, air filter) as close as possible to the tool. Adjust the oiler so that one drop of oil will be provided for every 50 staples.

When an air set is not used, oil the tool with pneumatic tool oil by placing 2 (two) or 3 (three) drops into the air fitting.

This should be done before and after use. For proper lubrication, the tool must be fired a couple of times after pneumatic tool oil is introduced.

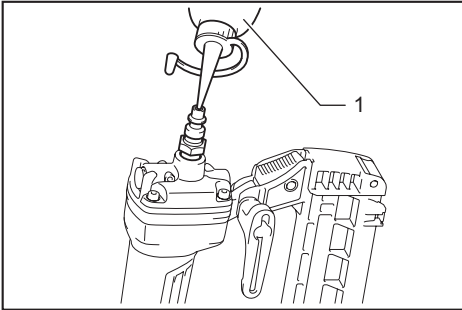

► 1. Pneumatic tool oil

FUNCTIONAL DESCRIPTION

CAUTION: Before adjusting or checking function on the tool, always return the trigger and disconnect the air hose from the tool.

Adjusting depth of stapling

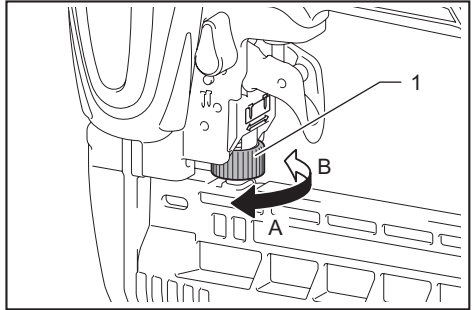

► 1. Adjuster

To adjust the depth of stapling, turn the adjuster. The depth of stapling is the deepest when the adjuster is turned fully in the A direction shown in the figure. It will become shallower as the adjuster is turned in the B direction. If staples cannot be driven deep enough even when the adjuster is turned fully in the A direction, increase the air pressure.

If staples are driven too deep even when the adjuster is turned fully in the B direction, decrease the air pressure.

Generally speaking, the tool service life will be longer when the tool is used with lower air pressure and the adjuster set to deeper depth of staple driving.

Hook

CAUTION: Never hook the tool at high location or on potentially unstable surface.

CAUTION: Do not hang the hook from the waist belt. If the stapler accidentally drops, it may result in misfiring and personal injuries.

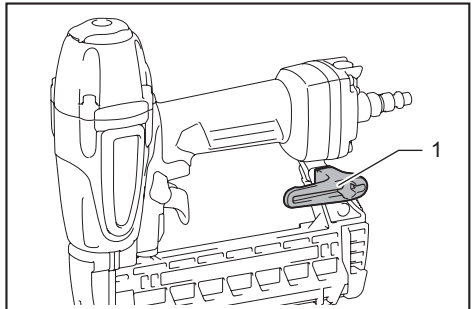

► 1. Hook

The hook is convenient for hanging the tool temporarily.

Air duster

CAUTION: Do not aim the ejection port of the air duster to someone. Also, keep your hands and foot away from the ejection port. If the air duster button is accidentally pushed, it may cause a personal injury.

CAUTION: Always check your surroundings before using the air duster. Blown dust or objects may hit someone.

CAUTION: Do not connect or disconnect the air hose while pushing the air duster button.

The air supplied to the tool can also be used as an air duster. You can clean the work area by pressing the button on the grip end.

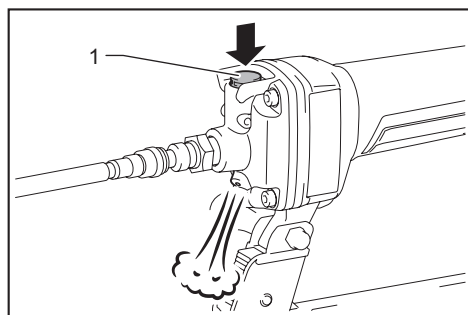

► 1. Button

NOTICE: After using the air duster, the driving force of the tool will temporarily decline. Wait until the air pressure recovers in this case.

NOTICE: Perform a test blow if you use the air duster immediately after the oil was applied. The oil may be sprayed with the air.

ASSEMBLY

CAUTION: Before carrying out any work on the tool, always return the trigger and disconnect the air hose from the tool.

CAUTION: Load the same type, size and uniform length of staples when loading multiple strips of staples in the magazine.

Loading stapler

NOTE: Always hold the rear of the sliding door when you press the lever. The sliding door opens suddenly with the lever pressed when staples are stored in the magazine.

1. Press the lever and open the sliding door of the magazine.

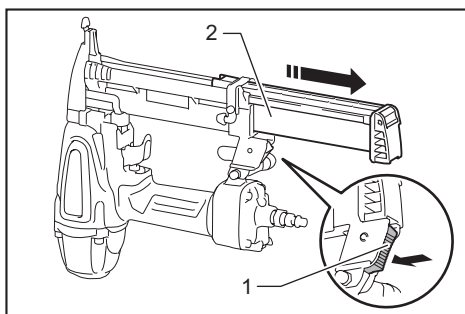

► 1. Lever 2. Sliding door

2. Insert a strip of staples into the opening of the magazine all the way.

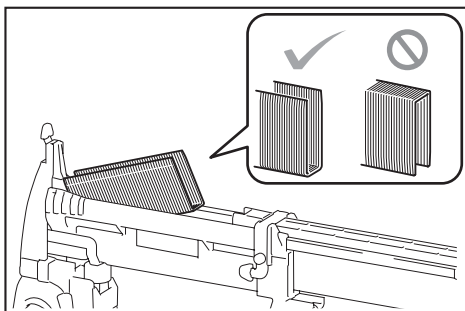

3. Close the sliding door until the sliding door is locked.

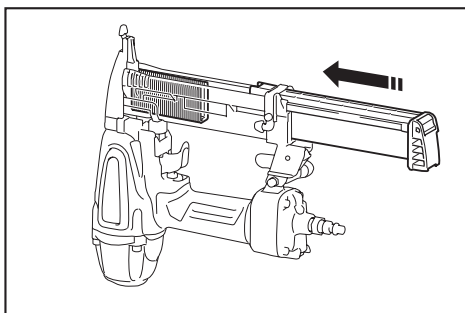

Removing staples

To remove staples, follow the procedures of “Loading stapler” in reverse.

Nose adapter

To prevent the surface of workpiece from being scratched or damaged, use the nose adapter.

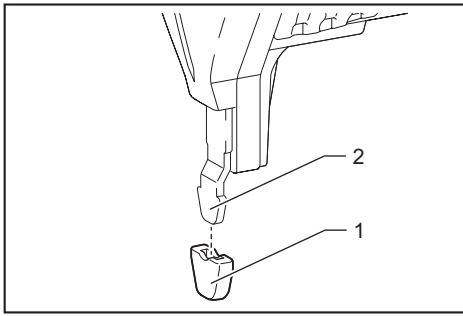

► 1. Nose adapter 2. Contact element

A spare nose adapter is stored in the place shown in the figure.

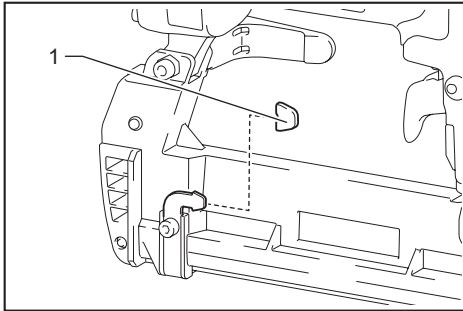

► 1. Spare nose adapter

Connecting air hose

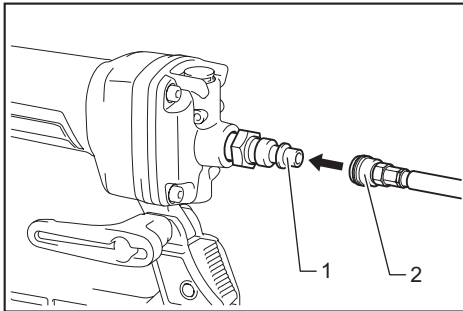

► 1. Air fitting 2. Air socket

Slip the air socket of the air hose onto the air fitting on the stapler. Be sure that the air socket locks firmly into position when installed onto the air fitting. A hose coupling must be installed on or near the tool in such a way that the pressure reservoir will discharge at the time the air supply coupling is disconnected.

OPERATION

CAUTION: Make sure all safety systems are in working order before operation.

Selecting the operation mode

CAUTION: Always make sure that the actuation mode selector is properly set to the position for the desired stapling mode before stapling.

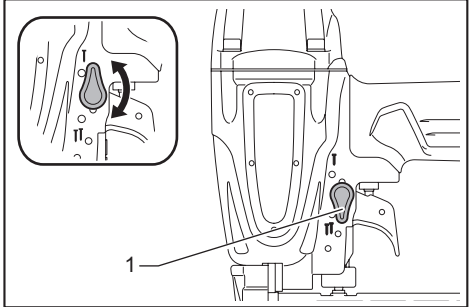

► 1. Actuation mode selector

Single sequential actuation mode:

You can drive one staple by one sequential operation. Select this mode when driving a staple carefully and accurately.

To choose this mode, set the actuation mode selector to the position.

Contact actuation mode:

You can drive staples repetitively by placing the contact element with the trigger held.

To choose this mode, set the actuation mode selector to the position.

Single sequential actuation

Place the contact element against the workpiece and pull the trigger fully.

After stapling, release the contact element, and then release the trigger.

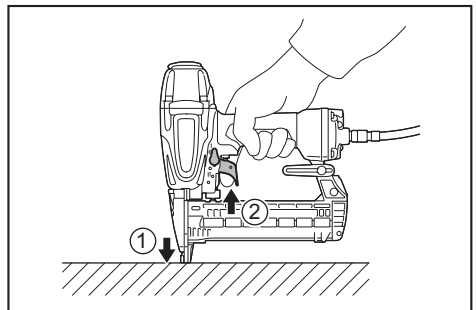

CAUTION: Do not place the contact element against the workpiece with excessive force. Also, pull the trigger fully and hold it on for 1-2 seconds after stapling.

Even in the “Single sequential actuation” mode, half-pulled trigger causes an unexpected stapling, when the contact element re-contacts the workpiece.

Contact actuation

Pull the trigger first and then place the contact element against the workpiece.

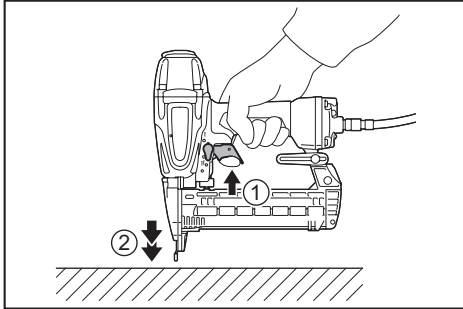

Empty indicator

When the remaining number of staples in the magazine becomes low, the empty indicator turns to red. Reload the staples when the empty indicator becomes red.

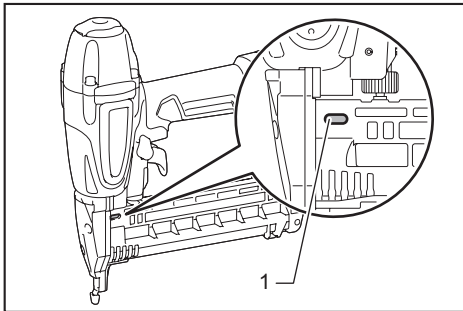

► 1. Empty indicator

Removing jammed staples

CAUTION: Always return the trigger and disconnect the hose before removing jammed staples.

CAUTION: Do not use deformed staples or strip of staples. Failure to do so causes poor staple feeding.

NOTE: Always hold the rear of the sliding door when you press the lever. The sliding door opens suddenly with the lever pressed when staples are stored in the magazine.

Follow the procedure of “Removing staples” to remove the strip of staples, and remove jammed staples from the staple rail.

MAINTENANCE

CAUTION: Before attempting to perform inspection or maintenance, always return the trigger and disconnect the air hose from the tool.

NOTICE: Never use gasoline, benzine, thinner, alcohol or the like. Discoloration, deformation or cracks may result.

Staples

Handle staple strips and their box carefully. If the staple strips have been handled roughly, they may be out of shape, causing poor staple feed.

Avoid storing staples in a very humid or hot place or place exposed to direct sunlight.

Maintenance of stapler

Always check the tool for its overall condition and loose screws before operation. Tighten as required.

With tool disconnected, make daily inspection to assure free movement of the contact element and trigger. Do not use tool if the contact element or trigger sticks or binds.

When the tool is not to be used for an extended period of time, lubricate the tool using pneumatic tool oil and store the tool in a safe place. Avoid exposure to direct sunlight and/or humid or hot environment.

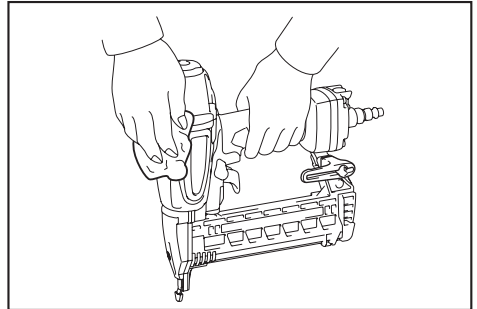

Maintenance of compressor, air set and air hose

After operation, always drain the compressor tank and the air filter. If moisture is allowed to enter the tool, it may result in poor performance and possible tool failure.

OPTIONAL ACCESSORIES

CAUTION: These accessories or attachments are recommended for use with your Makita tool specified in this manual. The use of any other accessories or attachments might present a risk of injury to persons. Only use accessory or attachment for its stated purpose.

If you need any assistance for more details regarding these accessories, ask your local Makita Service Center.

- Staples
- Air hose
- Safety goggles

NOTE: Some items in the list may be included in the tool package as standard accessories. They may differ from country to country.

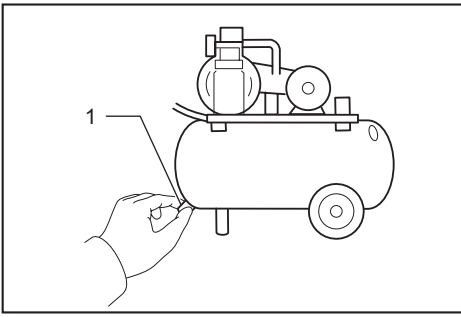

► 1. Drain cock

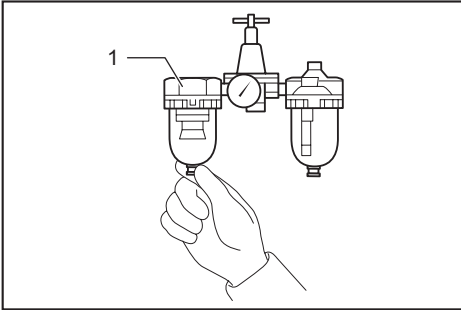

► 1. Air filter

Check regularly to see if there is sufficient pneumatic oil in the oiler of the air set. Failure to maintain sufficient lubrication will cause O-rings to wear quickly.

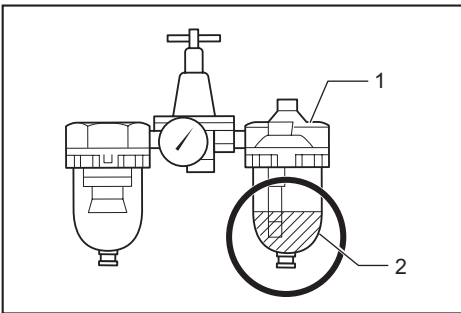

► 1. Oiler 2. Pneumatic oil

Keep the air hose away from heat (over 60°C, over 140°F), away from chemicals (thinner, strong acids or alkalis). Also, route the hose away from obstacles which it may become dangerously caught on during operation. Hoses must also be directed away from sharp edges and areas which may lead to damage or abrasion to the hose.

To maintain product SAFETY and RELIABILITY, repairs, any other maintenance or adjustment should be performed by Makita Authorized or Factory Service Centers, always using Makita replacement parts.

Makita Corporation
3-11-8, Sumiyoshi-cho,
Anjo, Aichi 446-8502 Japan
www.makita.com

AT638A-ENAU-1604
EN
20160624