

INSTRUCTION MANUAL

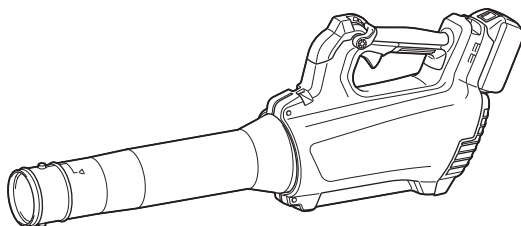

Cordless Blower

DUB184



Read before use.

SPECIFICATIONS

Model:		DUB184
Capacities	Air volume	0 - 13.0 m ³ /min
	Air speed (average)	0 - 43.2 m/s
	Air speed (max.)	0 - 52.1 m/s
Overall length (with front nozzle)		825 mm
Rated voltage		D.C. 18 V
Net weight		2.5 - 3.0 kg

- Due to our continuing program of research and development, the specifications herein are subject to change without notice.
- Specifications may differ from country to country.
- The weight may differ depending on the attachment(s), including the battery cartridge. The lightest and heaviest combination, according to EPTA-Procedure 01/2014, are shown in the table.

Applicable battery cartridge and charger

Battery cartridge	BL1815N / BL1820B / BL1830B / BL1840B / BL1850B / BL1860B
Charger	DC18RC / DC18RD / DC18RE / DC18SD / DC18SE / DC18SF / DC18SH

- Some of the battery cartridges and chargers listed above may not be available depending on your region of residence.

⚠ WARNING: Only use the battery cartridges and chargers listed above. Use of any other battery cartridges and chargers may cause injury and/or fire.







Recommended cord connected power source

Portable power pack	PDC01
---------------------	-------

- The cord connected power source(s) listed above may not be available depending on your region of residence.
- Before using the cord connected power source, read instruction and cautionary markings on them.

Symbols

The followings show the symbols which may be used for the equipment. Be sure that you understand their meaning before use.

	Take particular care and attention.
	Read instruction manual.
	Keep hands away from rotating parts.
	Keep bystanders away.
	Wear eye and ear protection.
	Do not expose to moisture.



Only for EU countries
 Due to the presence of hazardous components in the equipment, waste electrical and electronic equipment, accumulators and batteries may have a negative impact on the environment and human health. Do not dispose of electrical and electronic appliances or batteries with household waste! In accordance with the European Directive on waste electrical and electronic equipment and on accumulators and batteries and waste accumulators and batteries, as well as their adaptation to national law, waste electrical equipment, batteries and accumulators should be stored separately and delivered to a separate collection point for municipal waste, operating in accordance with the regulations on environmental protection. This is indicated by the symbol of the crossed-out wheeled bin placed on the equipment.

Intended use

The machine is intended for blowing dust.

Noise

The typical A-weighted noise level determined according to EN50636-2-100:

Sound pressure level (L_{pA}) : 86.6 dB(A)

Uncertainty (K) : 1.4 dB(A)

Sound power level (L_{WA}) : 93.5 dB (A)

Uncertainty (K) : 2.7 dB(A)

NOTE: The declared noise emission value(s) has been measured in accordance with a standard test method and may be used for comparing one tool with another.

NOTE: The declared noise emission value(s) may also be used in a preliminary assessment of exposure.

⚠WARNING: Wear ear protection.

⚠WARNING: The noise emission during actual use of the power tool can differ from the declared value(s) depending on the ways in which the tool is used especially what kind of workpiece is processed.

⚠WARNING: Be sure to identify safety measures to protect the operator that are based on an estimation of exposure in the actual conditions of use (taking account of all parts of the operating cycle such as the times when the tool is switched off and when it is running idle in addition to the trigger time).

Vibration

The vibration total value (tri-axial vector sum) determined according to EN50636-2-100:

Work mode: operation without load

Vibration emission (a_{hv}): 2.5 m/s² or less

Uncertainty (K): 1.5 m/s²

NOTE: The declared vibration total value(s) has been measured in accordance with a standard test method and may be used for comparing one tool with another.

NOTE: The declared vibration total value(s) may also be used in a preliminary assessment of exposure.

⚠WARNING: The vibration emission during actual use of the power tool can differ from the declared value(s) depending on the ways in which the tool is used especially what kind of workpiece is processed.

⚠WARNING: Be sure to identify safety measures to protect the operator that are based on an estimation of exposure in the actual conditions of use (taking account of all parts of the operating cycle such as the times when the tool is switched off and when it is running idle in addition to the trigger time).

EC Declaration of Conformity

For European countries only

The EC declaration of conformity is included as Annex A to this instruction manual.

SAFETY WARNINGS

Cordless Blower Safety Instructions

⚠WARNING: Read all safety warnings and all instructions. Failure to follow the warnings and instructions may result in electric shock, fire and/or serious injury.

Save all warnings and instructions for future reference.

Training

1. Read the instructions carefully. Be familiar with the controls and the correct use of the blower.
2. Never allow children, persons with reduced physical, sensory or mental capabilities or lack of experience and knowledge or people unfamiliar with these instructions to use the blower. Local regulations may restrict the age of the operator.
3. Never operate the blower while people, especially children, or pets are nearby.
4. Keep in mind that the operator or user is responsible for accidents or hazards occurring to other people or their property.

Preparation

1. Always wear substantial footwear and long trousers while operating the blower.
2. Do not wear loose clothing or jewellery that can be drawn into the air inlet. Keep long hair away from the air inlets.
3. Always wear protective goggles to protect your eyes from injury when using power tools. The goggles must comply with ANSI Z87.1 in the USA, EN 166 in Europe, or AS/NZS 1336 in Australia/New Zealand. In Australia/New Zealand, it is legally required to wear a face shield to protect your face, too.

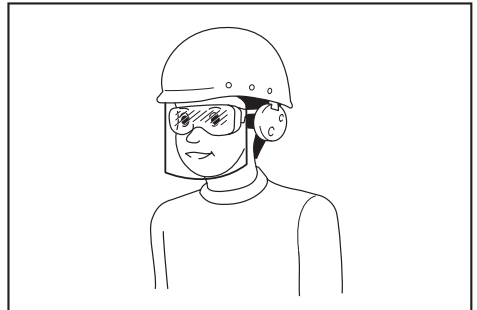

It is an employer's responsibility to enforce the use of appropriate safety protective equipments by the tool operators and by other persons in the immediate working area.

4. To prevent dust irritation the wearing of a face mask is recommended.
5. While operating the machine, always wear non-slip and protective footwear. Non-skid, closed-toed safety boots and shoes will reduce the risk of injury.
6. Use personal protective equipment. Always wear eye protection. Protective equipment such as a dust mask, non-skid safety shoes, hard hat or hearing protection used for appropriate conditions will reduce personal injuries.

Operation

1. Switch off the blower and remove the battery cartridge and make sure that all moving parts have come to a complete stop
 - whenever you leave the blower.
 - before clearing blockages.
 - before checking, cleaning or working on the blower.
 - if the blower starts to vibrate abnormally.
2. Operate the blower only in daylight or in good artificial light.
3. Do not overreach and keep proper balance and footing at all times.
4. Always be sure of your footing on slopes.
5. Walk, never run.
6. Keep all cooling air inlets clear of debris.
7. Never blow debris in the direction of bystanders.
8. Operate the blower in a recommended position and on a firm surface.
9. Do not operate the blower at high places.
10. Never point the nozzle at anyone in the vicinity when using the blower.
11. Never block suction inlet and/or blower outlet.
 - Be careful not to block suction inlet or blower outlet with dust or dirt when operating in dusty area.
 - Do not use nozzles other than the nozzles provided by Makita.
 - Do not use the blower to inflate balls, rubber boat or the similar.
12. Do not operate the blower near open window, etc.
13. Operating the blower only at reasonable hours is recommended - not early in the morning or late at night when people might be disturbed.
14. Using rakes and brooms to loosen debris before blowing is recommended.
15. If the blower strikes any foreign objects or should start making any unusual noise or vibration, immediately switch off the blower to stop it. Remove the battery cartridge from the blower and inspect the blower for damage before restarting and operating the blower. If the blower is damaged, ask Makita Authorized Service Centers for repair.
16. Do not insert fingers or other objects into suction inlet or blower outlet.
17. Prevent unintentional starting. Ensure the switch is in the off-position before inserting battery cartridge, picking up or carrying the blower. Carrying the blower with your finger on the switch or energizing the blower that has the switch on invites accidents.
18. Never blow dangerous materials, such as nails, fragments of glass, or blades.
19. Do not operate the blower near flammable materials.
20. Avoid operating the blower for a long time in low temperature environment.

Maintenance and storage

1. Keep all nuts, bolts and screws tight to be sure the blower is in safe working condition.

2. If the parts are worn or damaged, replace them with parts provided by Makita.
3. Store the blower in a dry place out of the reach of children.
4. When you stop the blower for inspection, servicing, storage, or changing accessory, switch off the blower and make sure that all moving parts come to a complete stop, and remove the battery cartridge. Cool down the blower before making any work on the blower. Maintain the blower with care and keep it clean.
5. Always cool down the blower before storing.
6. Do not expose the blower to rain. Store the blower indoors.
7. When you lift the blower, be sure to bend your knees and be careful not to hurt your back.

Battery tool use and care

1. Recharge only with the charger specified by the manufacturer. A charger that is suitable for one type of battery pack may create a risk of fire when used with another battery pack.
2. Use power tools only with specifically designated battery packs. Use of any other battery packs may create a risk of injury and fire.
3. When battery pack is not in use, keep it away from other metal objects, like paper clips, coins, keys, nails, screws or other small metal objects, that can make a connection from one terminal to another. Shorting the battery terminals together may cause burns or a fire.
4. Under abusive conditions, liquid may be ejected from the battery; avoid contact. If contact accidentally occurs, flush with water. If liquid contacts eyes, additionally seek medical help. Liquid ejected from the battery may cause irritation or burns.
5. Do not use a battery pack or tool that is damaged or modified. Damaged or modified batteries may exhibit unpredictable behaviour resulting in fire, explosion or risk of injury.
6. Do not expose a battery pack or tool to fire or excessive temperature. Exposure to fire or temperature above 130 °C may cause explosion.
7. Follow all charging instructions and do not charge the battery pack or tool outside the temperature range specified in the instructions. Charging improperly or at temperatures outside the specified range may damage the battery and increase the risk of fire.

Electrical and battery safety

1. Do not dispose of the battery(ies) in a fire. The cell may explode. Check with local codes for possible special disposal instructions.
2. Do not open or mutilate the battery(ies). Released electrolyte is corrosive and may cause damage to the eyes or skin. It may be toxic if swallowed.
3. Do not charge battery in rain, or in wet locations.
4. Do not charge the battery outdoors.
5. Do not handle charger, including charger plug, and charger terminals with wet hands.

Service

1. **Have your power tool serviced by a qualified repair person using only identical replacement parts.** This will ensure that the safety of the power tool is maintained.
2. **Never service damaged battery packs.** Service of battery packs should only be performed by the manufacturer or authorized service providers.

SAVE THESE INSTRUCTIONS.

⚠WARNING: DO NOT let comfort or familiarity with product (gained from repeated use) replace strict adherence to safety rules for the subject product.

MISUSE or failure to follow the safety rules stated in this instruction manual may cause serious personal injury.

Important safety instructions for battery cartridge

1. Before using battery cartridge, read all instructions and cautionary markings on (1) battery charger, (2) battery, and (3) product using battery.
2. Do not disassemble or tamper with the battery cartridge. It may result in a fire, excessive heat, or explosion.
3. If operating time has become excessively shorter, stop operating immediately. It may result in a risk of overheating, possible burns and even an explosion.
4. If electrolyte gets into your eyes, rinse them out with clear water and seek medical attention right away. It may result in loss of your eyesight.
5. Do not short the battery cartridge:
 - (1) Do not touch the terminals with any conductive material.
 - (2) Avoid storing battery cartridge in a container with other metal objects such as nails, coins, etc.
 - (3) Do not expose battery cartridge to water or rain.

A battery short can cause a large current flow, overheating, possible burns and even a breakdown.
6. Do not store and use the tool and battery cartridge in locations where the temperature may reach or exceed 50 °C (122 °F).
7. Do not incinerate the battery cartridge even if it is severely damaged or is completely worn out. The battery cartridge can explode in a fire.
8. Do not nail, cut, crush, throw, drop the battery cartridge, or hit against a hard object to the battery cartridge. Such conduct may result in a fire, excessive heat, or explosion.
9. Do not use a damaged battery.
10. The contained lithium-ion batteries are subject to the Dangerous Goods Legislation requirements.

For commercial transports e.g. by third parties, forwarding agents, special requirement on packaging and labeling must be observed.

For preparation of the item being shipped, consulting an expert for hazardous material is required. Please also observe possibly more detailed national regulations.

Tape or mask off open contacts and pack up the battery in such a manner that it cannot move around in the packaging.

11. **When disposing the battery cartridge, remove it from the tool and dispose of it in a safe place. Follow your local regulations relating to disposal of battery.**
12. **Use the batteries only with the products specified by Makita.** Installing the batteries to non-compliant products may result in a fire, excessive heat, explosion, or leak of electrolyte.
13. **If the tool is not used for a long period of time, the battery must be removed from the tool.**
14. **During and after use, the battery cartridge may take on heat which can cause burns or low temperature burns. Pay attention to the handling of hot battery cartridges.**
15. **Do not touch the terminal of the tool immediately after use as it may get hot enough to cause burns.**
16. **Do not allow chips, dust, or soil stuck into the terminals, holes, and grooves of the battery cartridge.** It may result in poor performance or breakdown of the tool or battery cartridge.
17. **Unless the tool supports the use near high-voltage electrical power lines, do not use the battery cartridge near high-voltage electrical power lines.** It may result in a malfunction or breakdown of the tool or battery cartridge.
18. **Keep the battery away from children.**

SAVE THESE INSTRUCTIONS.

⚠CAUTION: Only use genuine Makita batteries. Use of non-genuine Makita batteries, or batteries that have been altered, may result in the battery bursting causing fires, personal injury and damage. It will also void the Makita warranty for the Makita tool and charger.

Tips for maintaining maximum battery life

1. Charge the battery cartridge before completely discharged. Always stop tool operation and charge the battery cartridge when you notice less tool power.
2. Never recharge a fully charged battery cartridge. Overcharging shortens the battery service life.
3. Charge the battery cartridge with room temperature at 10 °C - 40 °C (50 °F - 104 °F). Let a hot battery cartridge cool down before charging it.
4. When not using the battery cartridge, remove it from the tool or the charger.
5. Charge the battery cartridge if you do not use it for a long period (more than six months).

ASSEMBLY

CAUTION: Always be sure that the machine is switched off and the battery cartridge is removed before carrying out any work on the machine.

Installing the front nozzle

1. Loosen 2 screws with the hex wrench, and then pull the screws all the way.

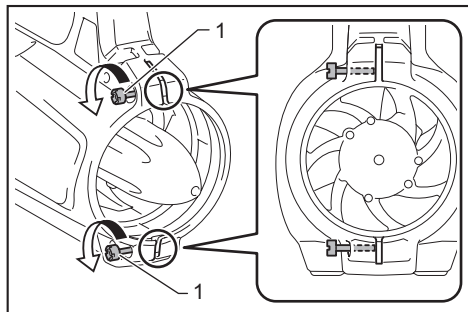

► 1. Screw

2. Make sure that the Makita logo on the front nozzle is facing the direction shown in the figure, and then attach the front nozzle to the machine.

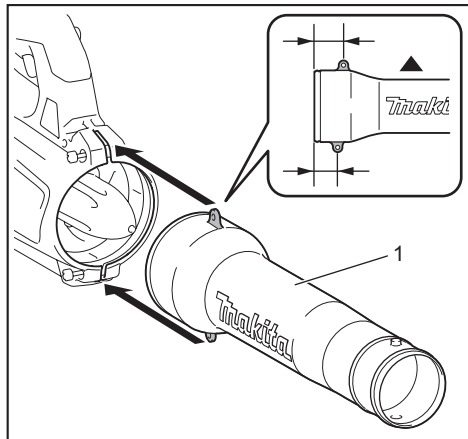

► 1. Front nozzle

3. Tighten the screws with the hex wrench.

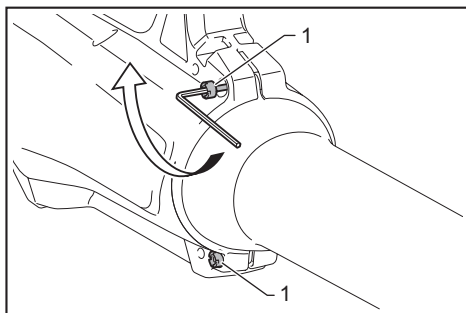

► 1. Screw

Installing the flat nozzle or extension nozzle

Optional accessory

1. Attach the adapter pipe to the front nozzle, and then turn it clockwise to lock it into place.

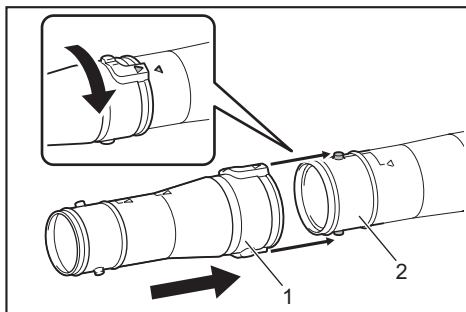

► 1. Adapter pipe 2. Front nozzle

2. Attach the flat nozzle or extension nozzle to the adapter pipe, and then turn it to lock it into place.

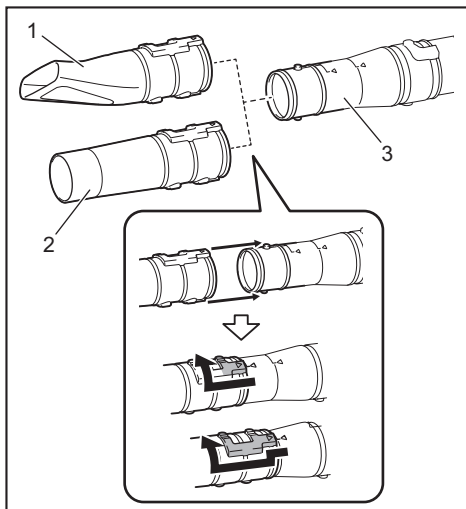

► 1. Flat nozzle 2. Extension nozzle 3. Adapter pipe

Installing the gutter nozzle

Optional accessory

The gutter nozzle can be installed on the blower. The adapter pipe designed exclusively for this model is required to install the gutter nozzle.

For more details, refer to the instruction manual provided with the gutter nozzle.

Attaching the shoulder strap

Optional accessory

CAUTION: Be sure to attach the hooks of the shoulder strap to the machine securely. If the hooks are attached incompletely, they may come off and cause an injury.

CAUTION: Be sure to use the shoulder strap dedicated to this machine. Using other shoulder strap may cause an injury.

CAUTION: When you use the machine in combination of the backpack-type power supply such as portable power pack, do not use the shoulder strap included in the machine package.

If you put on the shoulder strap included in the machine package and the shoulder harness of the backpack-type power supply at the same time, removing the machine or backpack-type power supply is difficult in case of an emergency, and it may cause an accident or injury.

Attach the hooks of the shoulder strap to the machine as shown in the figure.

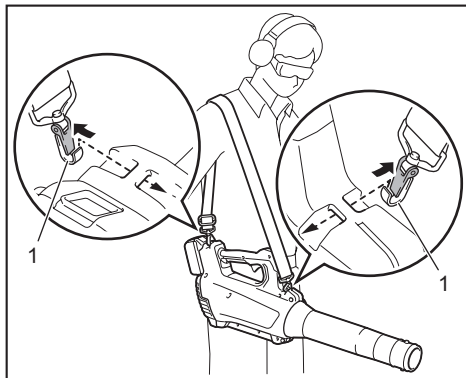

► 1. Hook

You can also attach the shoulder strap to the machine as shown in the figure by attaching one end of the shoulder strap to the buckle of the shoulder strap.

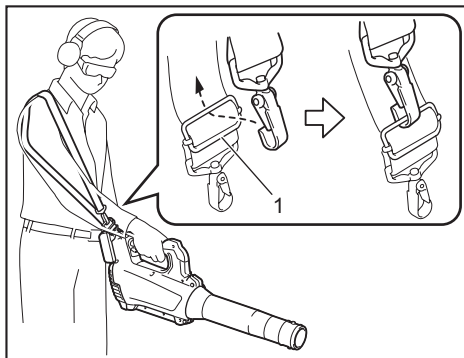

► 1. Buckle

FUNCTIONAL DESCRIPTION

CAUTION: Always be sure that the machine is switched off and the battery cartridge is removed before adjusting or checking function on the machine.

Installing or removing battery cartridge

CAUTION: Always switch off the machine before installing or removing of the battery cartridge.

CAUTION: Hold the machine and the battery cartridge firmly when installing or removing battery cartridge. Failure to hold the machine and the battery cartridge firmly may cause them to slip off your hands and result in damage to the machine and battery cartridge and a personal injury.

CAUTION: Always install the battery cartridge fully until the red indicator cannot be seen. If not, it may accidentally fall out of the machine, causing injury to you or someone around you.

CAUTION: Do not install the battery cartridge forcibly. If the cartridge does not slide in easily, it is not being inserted correctly.

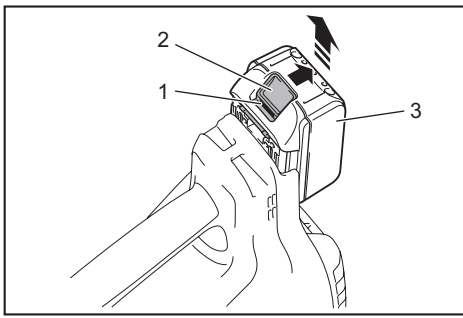

► 1. Red indicator 2. Button 3. Battery cartridge

To remove the battery cartridge, slide it from the machine while sliding the button on the front of the cartridge.

To install the battery cartridge, align the tongue on the battery cartridge with the groove in the housing and slip it into place. Insert it all the way until it locks in place with a little click. If you can see the red indicator on the upper side of the button, it is not locked completely.

Indicating the remaining battery capacity

Only for battery cartridges with the indicator

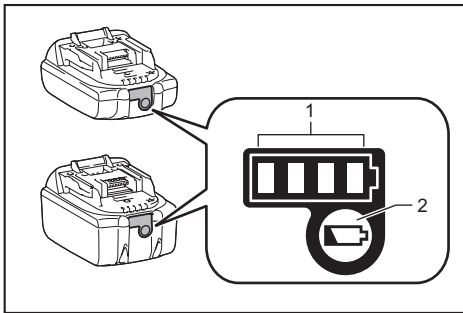

► 1. Indicator lamps 2. Check button

Press the check button on the battery cartridge to indicate the remaining battery capacity. The indicator lamps light up for a few seconds.

Indicator lamps			Remaining capacity
Lighted	Off	Blinking	
■	□	▧	75% to 100%
■ ■ ■ ■	□ □ □ □		
■ ■ ■	□ □ □	□	50% to 75%
■ ■	□ □ □	□	25% to 50%
■	□ □ □	□	0% to 25%
▧	□ □ □	□	Charge the battery.
■ ■ □ □	□ □ □ □	□ □	The battery may have malfunctioned.
□ □ ■ ■	□ □ □ □	□ □	

NOTE: Depending on the conditions of use and the ambient temperature, the indication may differ slightly from the actual capacity.

NOTE: The first (far left) indicator lamp will blink when the battery protection system works.

Machine/battery protection system

The machine is equipped with a machine/battery protection system. This system automatically cuts off power to the motor to extend machine and battery life. The machine will automatically stop during operation if the machine or battery is placed under one of the following conditions:

Overload protection

When the machine or battery is operated in a manner that causes it to draw an abnormally high current, the machine automatically stops without any indication. In this situation, turn the machine off and stop the application that caused the machine to become overloaded. Then turn the machine on to restart.

Overheat protection

When the machine or battery is overheated, the machine stops automatically. In this case, let the machine and battery cool before turning the machine on again.

Overdischarge protection

When the battery capacity is not enough, the machine stops automatically. In this case, remove the battery from the machine and charge the battery.

Switch action

⚠ WARNING: Before installing the battery cartridge into the machine, always check to see that the switch trigger actuates properly and returns to the "OFF" position when released.

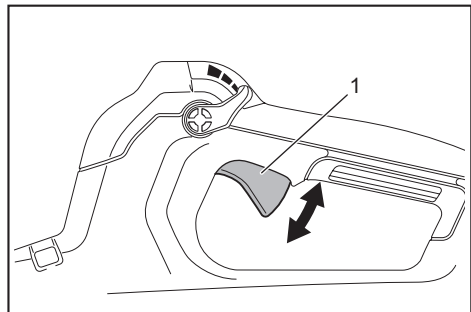

► 1. Switch trigger

To start the machine, simply pull the switch trigger. The speed increases by increasing pressure on the switch trigger. Release the switch trigger to stop.

Cruise control function

The cruise control function allows the operator to maintain a constant speed without pulling the trigger. To increase the speed, turn the control lever forward. To decrease the speed, turn the control lever backward.

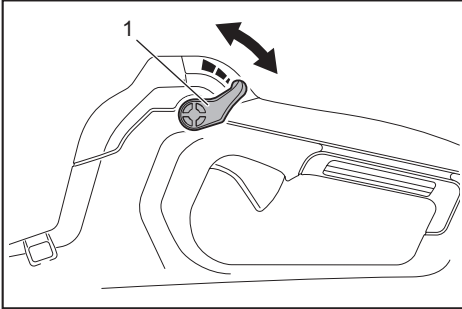

► 1. Control lever

Accidental re-start preventive function

Even if you install the battery cartridge while pulling the switch trigger, the machine does not start. To start the machine, first release the switch trigger and return the control lever fully, and then pull the switch trigger.

OPERATION

CAUTION: Do not place the machine on the ground while it is switched on. Sand or dust may enter from suction inlet and cause a malfunction or personal injury.

Hold the machine firmly with a hand and perform the blowing operation by moving it around slowly. When blowing around building, big stone or vehicle, direct the nozzle away from them. When performing an operation in a corner, start from the corner and then move to wide area.



MAINTENANCE

CAUTION: Always be sure that the machine is switched off and the battery cartridge is removed before attempting to perform inspection or maintenance.

To maintain product SAFETY and RELIABILITY, repairs, any other maintenance or adjustment should be performed by Makita Authorized or Factory Service Centers, always using Makita replacement parts.

Cleaning the machine

Clean the machine by wiping off dust with a dry cloth or one dipped in soapy water and wrung out.

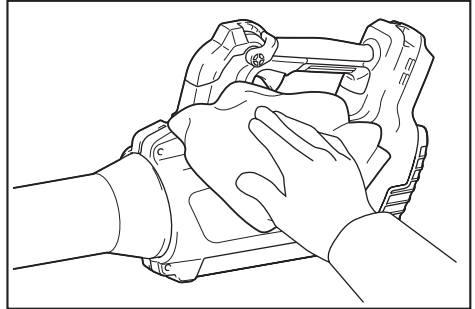

NOTICE: Never use gasoline, benzine, thinner, alcohol or the like. Discoloration, deformation or cracks may result.

Remove dust or dirt from the suction inlet at the rear of the machine.

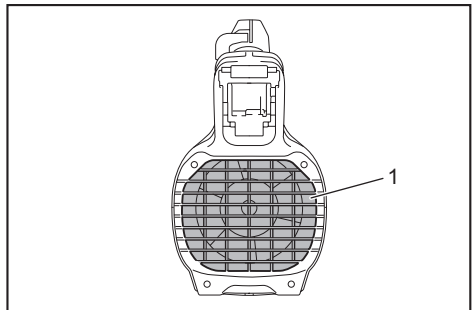

► 1. Suction inlet

Storage

The hook hole on the bottom of the machine is convenient for hanging the machine from a nail or screw on the wall. Store the machine in a place out of the reach of children and not exposed to moisture or rain.

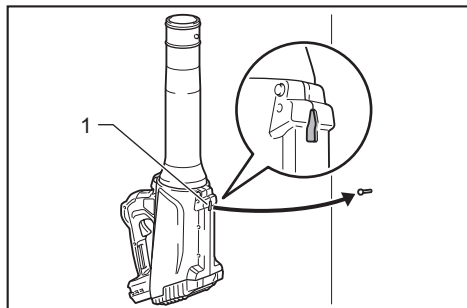

► 1. Hole

TROUBLESHOOTING

Before asking for repairs, conduct your own inspection first. If you find a problem that is not explained in the manual, do not attempt to dismantle the machine. Instead, ask Makita Authorized Service Centers, always using Makita replacement parts for repairs.

State of abnormality	Probable cause (malfunction)	Remedy
Motor does not run.	Battery cartridge is not installed.	Install the battery cartridge.
	Battery problem (under voltage)	Recharge the battery. If recharging is not effective, replace battery.
	The drive system does not work correctly.	Ask your local authorized service center for repair.
Motor stops running after a little use.	Battery's charge level is low.	Recharge the battery. If recharging is not effective, replace battery.
	Overheating.	Stop using the machine to allow it to cool down.
The machine does not reach the maximum speed.	Battery is installed improperly.	Install the battery cartridge as described in this manual.
	Battery power is dropping.	Recharge the battery. If recharging is not effective, replace battery.
	The drive system does not work correctly.	Ask your local authorized service center for repair.
Abnormal vibration: ⇒ stop the machine immediately!	The drive system does not work correctly.	Ask your local authorized service center for repair.
Motor cannot stop: ⇒ Remove the battery immediately!	Electric or electronic malfunction.	Remove the battery and ask your local authorized service center for repair.

OPTIONAL ACCESSORIES

⚠ CAUTION: These accessories or attachments are recommended for use with your Makita product specified in this manual. The use of any other accessories or attachments might present a risk of injury to persons. Only use accessory or attachment for its stated purpose.

If you need any assistance for more details regarding these accessories, ask your local Makita Service Center.

- Adapter pipe
- Extension nozzle
- Flat nozzle
- Gutter nozzle
- Shoulder strap
- Makita genuine battery and charger

NOTE: Some items in the list may be included in the product package as standard accessories. They may differ from country to country.

Makita Europe N.V. Jan-Baptist Vinkstraat 2,
3070 Kortenberg, Belgium

Makita Corporation 3-11-8, Sumiyoshi-cho,
Anjo, Aichi 446-8502 Japan

www.makita.com

885733B222 EN 20210223
