

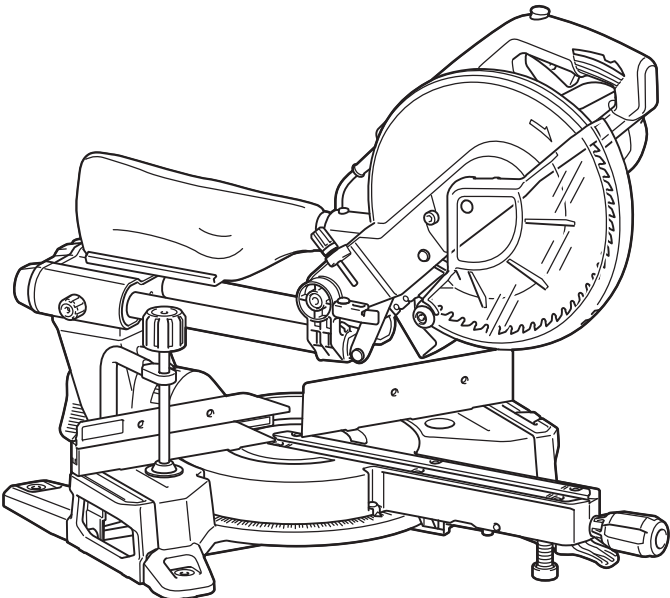

EN	Slide Compound Miter Saw	INSTRUCTION MANUAL	2
HE	מסור גרונג עם פנדל	חוברת הוראות	51

LS1110F



SPECIFICATIONS

Model:		LS1110F
Blade diameter	European countries	260 mm
	Countries other than Europe	255 mm - 260 mm
Hole diameter	European countries	30 mm
	Countries other than Europe	25.4 mm
Max. kerf thickness of the saw blade		3.2 mm
Max. miter angle		Left 47°, Right 47°
Max. bevel angle		Left 47°, Right 2°
No load speed (RPM)		4,500 min ⁻¹
Dimensions (L x W x H)		745 mm x 497 mm x 565 mm
Net weight		16.4 kg
Safety class		□/II









- Due to our continuing program of research and development, the specifications herein are subject to change without notice.
- Specifications may differ from country to country.
- Weight according to EPTA-Procedure 01/2014

Cutting capacities (H x W) with ø 260 mm saw blade

Miter angle	Bevel angle		
	45° (left)	0°	2° (right)
0°	50 mm x 310 mm	91 mm x 310 mm	85 mm x 310 mm
45° (left and right)	50 mm x 220 mm	91 mm x 220 mm	-

Symbols

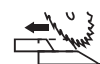
The followings show the symbols which may be used for the equipment. Be sure that you understand their meaning before use.

	Read instruction manual.
	DOUBLE INSULATION
	Wear safety glasses.
	To avoid injury from flying debris, keep holding the saw head down, after making cuts, until the saw blade has come to a complete stop.
	When performing slide cut, first pull carriage fully and press down handle, then push carriage toward the guide fence.
	Do not place hand or fingers close to the saw blade.
	Adjust sliding fences clear of saw blade and blade guard properly.
	Do not stare at operating lamp.



Only for EU countries

Due to the presence of hazardous components in the equipment, used electrical and electronic equipment may have a negative impact on the environment and human health.

Do not dispose of electrical and electronic appliances with household waste! In accordance with the European Directive on waste electrical and electronic equipment and its adaptation to national law, used electrical and electronic equipment should be collected separately and delivered to a separate collection point for municipal waste, operating in accordance with the environmental protection regulations.

This is indicated by the symbol of the crossed-out wheeled bin placed on the equipment.

Intended use

The tool is intended for accurate straight and miter cutting in wood. With appropriate saw blades, aluminum can also be sawed. For details, according to the section for OPERATION.

Power supply

The tool should be connected only to a power supply of the same voltage as indicated on the nameplate, and can only be operated on single-phase AC supply. They are double-insulated and can, therefore, also be used from sockets without earth wire.

SAFETY WARNINGS

General power tool safety warnings

⚠️ WARNING Read all safety warnings, instructions, illustrations and specifications provided with this power tool. Failure to follow all instructions listed below may result in electric shock, fire and/or serious injury.

Save all warnings and instructions for future reference.

The term “power tool” in the warnings refers to your mains-operated (corded) power tool or battery-operated (cordless) power tool.

Work area safety

1. **Keep work area clean and well lit.** Cluttered or dark areas invite accidents.
2. **Do not operate power tools in explosive atmospheres, such as in the presence of flammable liquids, gases or dust.** Power tools create sparks which may ignite the dust or fumes.
3. **Keep children and bystanders away while operating a power tool.** Distractions can cause you to lose control.

Electrical safety

1. **Power tool plugs must match the outlet. Never modify the plug in any way. Do not use any adapter plugs with earthed (grounded) power tools.** Unmodified plugs and matching outlets will reduce risk of electric shock.
2. **Avoid body contact with earthed or grounded surfaces, such as pipes, radiators, ranges and refrigerators.** There is an increased risk of electric shock if your body is earthed or grounded.
3. **Do not expose power tools to rain or wet conditions.** Water entering a power tool will increase the risk of electric shock.
4. **Do not abuse the cord. Never use the cord for carrying, pulling or unplugging the power tool. Keep cord away from heat, oil, sharp edges or moving parts.** Damaged or entangled cords increase the risk of electric shock.
5. **When operating a power tool outdoors, use an extension cord suitable for outdoor use.** Use of a cord suitable for outdoor use reduces the risk of electric shock.
6. **If operating a power tool in a damp location is unavoidable, use a residual current device (RCD) protected supply.** Use of an RCD reduces the risk of electric shock.
7. **Use of power supply via an RCD with a rated residual current of 30 mA or less is always recommended.**
8. **Power tools can produce electromagnetic fields (EMF) that are not harmful to the user.** However, users of pacemakers and other similar medical devices should contact the maker of their device and/or doctor for advice before operating this power tool.
9. **Do not touch the power plug with wet hands.**

10. **If the cord is damaged, have it replaced by the manufacturer or his agent in order to avoid a safety hazard.**

Personal safety

1. **Stay alert, watch what you are doing and use common sense when operating a power tool. Do not use a power tool while you are tired or under the influence of drugs, alcohol or medication.** A moment of inattention while operating power tools may result in serious personal injury.
2. **Use personal protective equipment. Always wear eye protection.** Protective equipment such as a dust mask, non-skid safety shoes, hard hat or hearing protection used for appropriate conditions will reduce personal injuries.
3. **Prevent unintentional starting. Ensure the switch is in the off-position before connecting to power source and/or battery pack, picking up or carrying the tool.** Carrying power tools with your finger on the switch or energising power tools that have the switch on invites accidents.
4. **Remove any adjusting key or wrench before turning the power tool on.** A wrench or a key left attached to a rotating part of the power tool may result in personal injury.
5. **Do not overreach. Keep proper footing and balance at all times.** This enables better control of the power tool in unexpected situations.
6. **Dress properly. Do not wear loose clothing or jewellery. Keep your hair and clothing away from moving parts.** Loose clothes, jewellery or long hair can be caught in moving parts.
7. **If devices are provided for the connection of dust extraction and collection facilities, ensure these are connected and properly used.** Use of dust collection can reduce dust-related hazards.
8. **Do not let familiarity gained from frequent use of tools allow you to become complacent and ignore tool safety principles.** A careless action can cause severe injury within a fraction of a second.
9. **Always wear protective goggles to protect your eyes from injury when using power tools. The goggles must comply with ANSI Z87.1 in the USA, EN 166 in Europe, or AS/NZS 1336 in Australia/New Zealand. In Australia/New Zealand, it is legally required to wear a face shield to protect your face, too.**

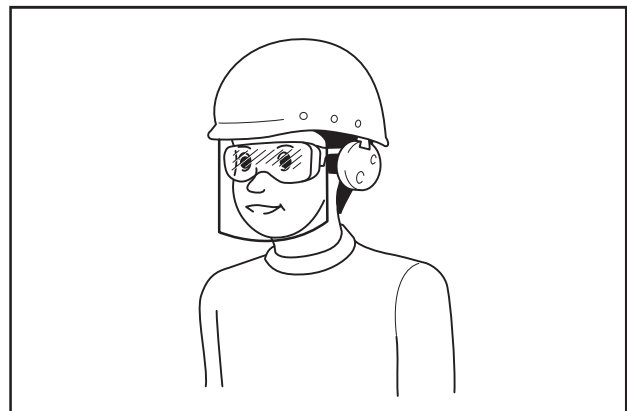

It is an employer's responsibility to enforce the use of appropriate safety protective equipments by the tool operators and by other persons in the immediate working area.

Power tool use and care

1. **Do not force the power tool. Use the correct power tool for your application.** The correct power tool will do the job better and safer at the rate for which it was designed.
2. **Do not use the power tool if the switch does not turn it on and off.** Any power tool that cannot be controlled with the switch is dangerous and must be repaired.
3. **Disconnect the plug from the power source and/or remove the battery pack, if detachable, from the power tool before making any adjustments, changing accessories, or storing power tools.** Such preventive safety measures reduce the risk of starting the power tool accidentally.
4. **Store idle power tools out of the reach of children and do not allow persons unfamiliar with the power tool or these instructions to operate the power tool.** Power tools are dangerous in the hands of untrained users.
5. **Maintain power tools and accessories. Check for misalignment or binding of moving parts, breakage of parts and any other condition that may affect the power tool's operation. If damaged, have the power tool repaired before use.** Many accidents are caused by poorly maintained power tools.
6. **Keep cutting tools sharp and clean.** Properly maintained cutting tools with sharp cutting edges are less likely to bind and are easier to control.
7. **Use the power tool, accessories and tool bits etc. in accordance with these instructions, taking into account the working conditions and the work to be performed.** Use of the power tool for operations different from those intended could result in a hazardous situation.
8. **Keep handles and grasping surfaces dry, clean and free from oil and grease.** Slippery handles and grasping surfaces do not allow for safe handling and control of the tool in unexpected situations.
9. **When using the tool, do not wear cloth work gloves which may be entangled.** The entanglement of cloth work gloves in the moving parts may result in personal injury.

Service

1. **Have your power tool serviced by a qualified repair person using only identical replacement parts.** This will ensure that the safety of the power tool is maintained.
2. **Follow instruction for lubricating and changing accessories.**

Safety instructions for mitre saws

1. **Mitre saws are intended to cut wood or wood-like products, they cannot be used with abrasive cut-off wheels for cutting ferrous material such as bars, rods, studs, etc.** Abrasive dust causes moving parts such as the lower guard to jam. Sparks from abrasive cutting will burn the lower guard, the kerf insert and other plastic parts.
2. **Use clamps to support the workpiece whenever possible. If supporting the workpiece by hand, you must always keep your hand at least 100 mm from either side of the saw blade.** Do not use this saw to cut pieces that are too small to be securely clamped or held by hand. If your hand is placed too close to the saw blade, there is an increased risk of injury from blade contact.
3. **The workpiece must be stationary and clamped or held against both the fence and the table. Do not feed the workpiece into the blade or cut "freehand" in any way.** Unrestrained or moving workpieces could be thrown at high speeds, causing injury.
4. **Push the saw through the workpiece. Do not pull the saw through the workpiece. To make a cut, raise the saw head and pull it out over the workpiece without cutting, start the motor, press the saw head down and push the saw through the workpiece.** Cutting on the pull stroke is likely to cause the saw blade to climb on top of the workpiece and violently throw the blade assembly towards the operator.
5. **Never cross your hand over the intended line of cutting either in front or behind the saw blade.** Supporting the workpiece "cross handed" i.e. holding the workpiece to the right of the saw blade with your left hand or vice versa is very dangerous.

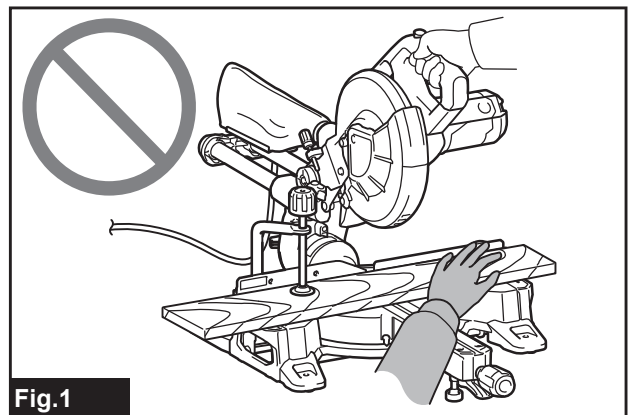

Fig.1

6. **Do not reach behind the fence with either hand closer than 100 mm from either side of the saw blade, to remove wood scraps, or for any other reason while the blade is spinning.** The proximity of the spinning saw blade to your hand may not be obvious and you may be seriously injured.

7. **Inspect your workpiece before cutting. If the workpiece is bowed or warped, clamp it with the outside bowed face toward the fence. Always make certain that there is no gap between the workpiece, fence and table along the line of the cut.** Bent or warped workpieces can twist or shift and may cause binding on the spinning saw blade while cutting. There should be no nails or foreign objects in the workpiece.
8. **Do not use the saw until the table is clear of all tools, wood scraps, etc., except for the workpiece.** Small debris or loose pieces of wood or other objects that contact the revolving blade can be thrown with high speed.
9. **Cut only one workpiece at a time.** Stacked multiple workpieces cannot be adequately clamped or braced and may bind on the blade or shift during cutting.
10. **Ensure the mitre saw is mounted or placed on a level, firm work surface before use.** A level and firm work surface reduces the risk of the mitre saw becoming unstable.
11. **Plan your work. Every time you change the bevel or mitre angle setting, make sure the adjustable fence is set correctly to support the workpiece and will not interfere with the blade or the guarding system.** Without turning the tool "ON" and with no workpiece on the table, move the saw blade through a complete simulated cut to assure there will be no interference or danger of cutting the fence.
12. **Provide adequate support such as table extensions, saw horses, etc. for a workpiece that is wider or longer than the table top.** Workpieces longer or wider than the mitre saw table can tip if not securely supported. If the cut-off piece or workpiece tips, it can lift the lower guard or be thrown by the spinning blade.
13. **Do not use another person as a substitute for a table extension or as additional support.** Unstable support for the workpiece can cause the blade to bind or the workpiece to shift during the cutting operation pulling you and the helper into the spinning blade.
14. **The cut-off piece must not be jammed or pressed by any means against the spinning saw blade.** If confined, i.e. using length stops, the cut-off piece could get wedged against the blade and thrown violently.
15. **Always use a clamp or a fixture designed to properly support round material such as rods or tubing.** Rods have a tendency to roll while being cut, causing the blade to "bite" and pull the work with your hand into the blade.
16. **Let the blade reach full speed before contacting the workpiece.** This will reduce the risk of the workpiece being thrown.
17. **If the workpiece or blade becomes jammed, turn the mitre saw off. Wait for all moving parts to stop and disconnect the plug from the power source and/or remove the battery pack. Then work to free the jammed material.** Continued sawing with a jammed workpiece could cause loss of control or damage to the mitre saw.
18. **After finishing the cut, release the switch, hold the saw head down and wait for the blade to stop before removing the cut-off piece.** Reaching with your hand near the coasting blade is dangerous.
19. **Hold the handle firmly when making an incomplete cut or when releasing the switch before the saw head is completely in the down position.** The braking action of the saw may cause the saw head to be suddenly pulled downward, causing a risk of injury.
20. **Only use the saw blade with the diameter that is marked on the tool or specified in the manual.** Use of an incorrectly sized saw blade may affect the proper guarding of the saw blade or guard operation which could result in serious personal injury.
21. **Only use the saw blades that are marked with a speed equal or higher than the speed marked on the tool.**
22. **Do not use the saw to cut materials other than specified.**
23. **(For European countries only) Always use the blade which conforms to EN847-1, if intended for wood and analogous materials.**

Additional instructions

1. **Make workshop kid proof with padlocks.**
2. **Never stand on the tool.** Serious injury could occur if the tool is tipped or if the cutting tool is unintentionally contacted.
3. **Never leave the tool running unattended. Turn the power off. Do not leave tool until it comes to a complete stop.**
4. **Do not operate saw without guards in place. Check blade guard for proper closing before each use. Do not operate saw if blade guard does not move freely and close instantly. Never clamp or tie the blade guard into the open position.**
5. **Keep hands out of path of saw blade. Avoid contact with any coasting saw blade. It can still cause severe injury.**
6. **To reduce the risk of injury, return carriage to the full rear position after each crosscut operation.**
7. **Always secure all moving portions before carrying the tool.**
8. **Stopper pin or stopper lever which locks the saw head down is for carrying and storage purposes only and not for any cutting operations.**
9. **Check the saw blade carefully for cracks or damage before operation. Replace cracked or damaged saw blade immediately. Gum and wood pitch hardened on saw blades slows saw and increases potential for kickback. Keep saw blade clean by first removing it from tool, then cleaning it with gum and pitch remover, hot water or kerosene. Never use gasoline to clean saw blade.**

10. While making a slide cut, KICKBACK can occur. KICKBACK occurs when the saw blade binds in the workpiece during a cutting operation and the saw blade is driven rapidly towards the operator. Loss of control and serious personal injury can result. If saw blade begins to bind during a cutting operation, do not continue to cut and release switch immediately.
11. Use only flanges specified for this tool.
12. Be careful not to damage the arbor, flanges (especially the installing surface) or bolt. Damage to these parts could result in saw blade breakage.
13. Make sure that the turn base is properly secured so it will not move during operation. Use the holes in the base to fasten the saw to a stable work platform or bench. NEVER use tool where operator positioning would be awkward.
14. Make sure the shaft lock is released before the switch is turned on.
15. Be sure that the saw blade does not contact the turn base in the lowest position.
16. Hold the handle firmly. Be aware that the saw moves up or down slightly during start-up and stopping.
17. Make sure the saw blade is not contacting the workpiece before the switch is turned on.
18. Before using the tool on an actual workpiece, let it run for a while. Watch for vibration or wobbling that could indicate poor installation or a poorly balanced saw blade.
19. Stop operation immediately if you notice anything abnormal.
20. Do not attempt to lock the trigger in the "ON" position.
21. Always use accessories recommended in this manual. Use of improper accessories such as abrasive wheels may cause an injury.
22. Some material contains chemicals which may be toxic. Take caution to prevent dust inhalation and skin contact. Follow material supplier safety data.

Additional safety rules for operating lamp

1. Do not look in the light or see the source of light directly.

SAVE THESE INSTRUCTIONS.

⚠ WARNING: DO NOT let comfort or familiarity with product (gained from repeated use) replace strict adherence to safety rules for the subject product. MISUSE or failure to follow the safety rules stated in this instruction manual may cause serious personal injury.

PARTS DESCRIPTION

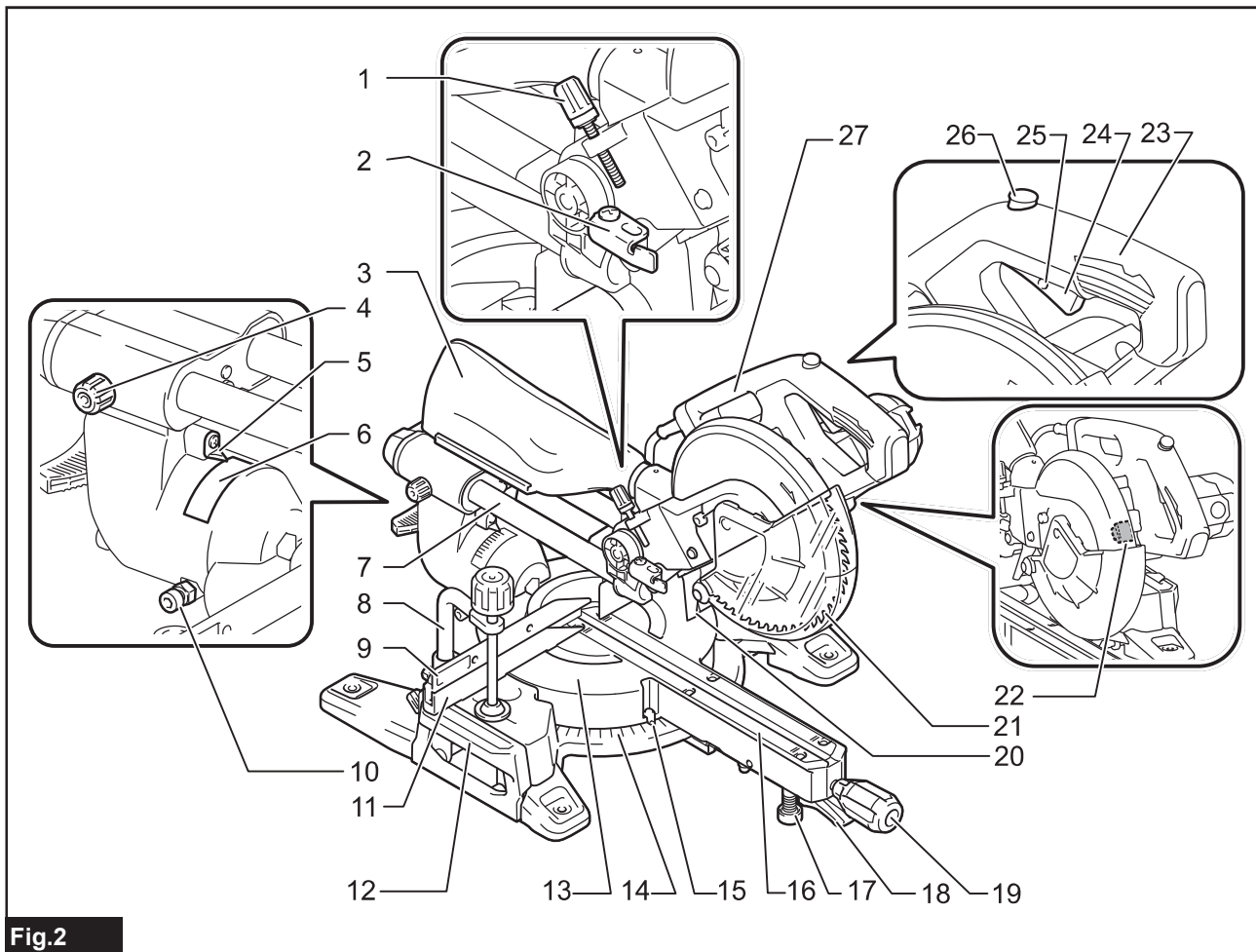

Fig.2

1	Adjusting screw (for lower limit position)	2	Stopper arm	3	Dust bag	4	Thumb screw (for carriage sliding)
5	Pointer (for bevel angle)	6	Bevel angle scale	7	Slide pole	8	Vertical vise
9	Sliding fence	10	0° adjusting bolt (for bevel angle)	11	Guide fence	12	Sub base
13	Turn base	14	Miter angle scale	15	Pointer (for miter angle)	16	Kerf board
17	Adjusting bolt (for turn base)	18	Lock lever (for turn base)	19	Grip (for turn base)	20	Dust collecting guard
21	Blade guard	22	Lamp	23	Handle (for operation)	24	Switch trigger
25	Hole for padlock	26	Lock-off button	27	Carry handle	-	-

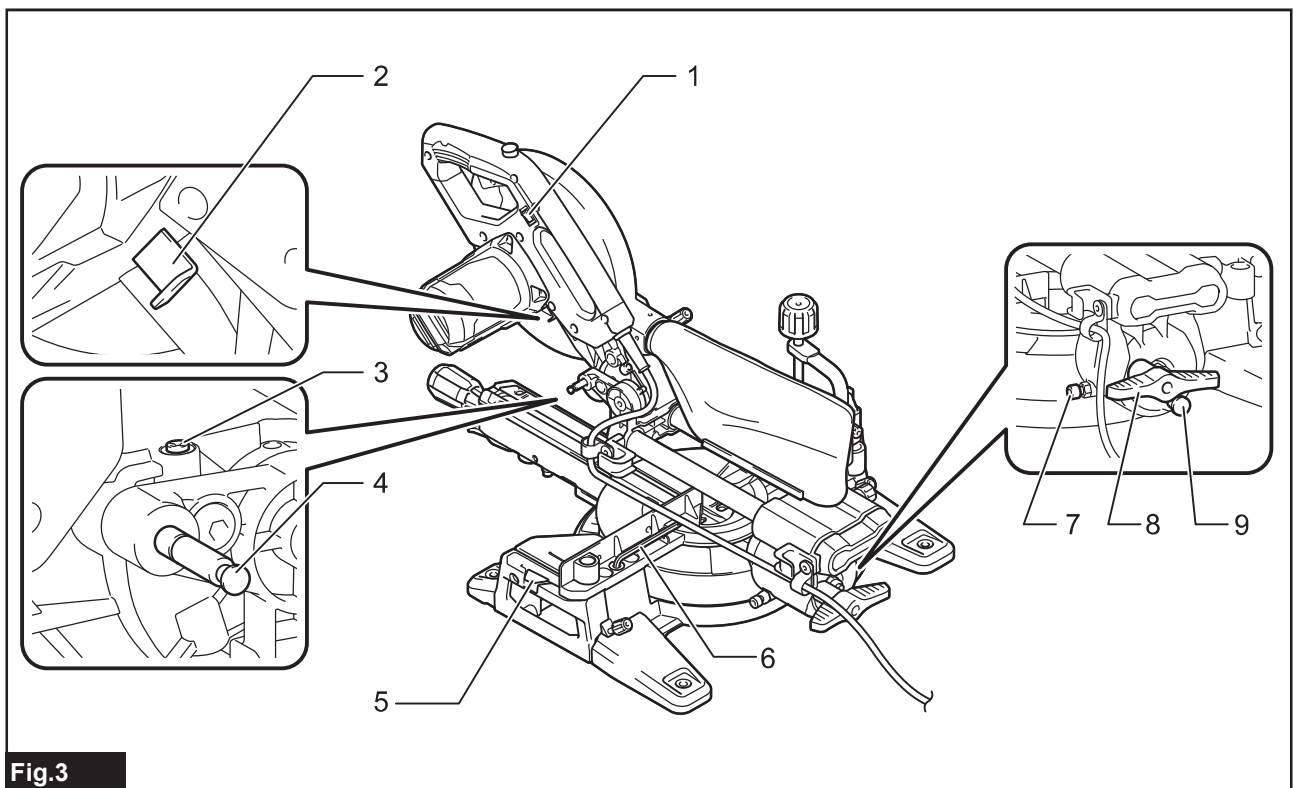

Fig.3

1	Lamp switch	2	Shaft lock	3	Adjusting bolt (for maximum cutting capacity)	4	Stopper pin (for carriage elevation)
5	Set plate	6	Hex wrench	7	45° adjusting bolt (for bevel angle)	8	Lever (for bevel angle)
9	Releasing button (for bevel angle)	-	-	-	-	-	-

INSTALLATION

Bench mounting

⚠ WARNING: Ensure that the tool does not move on the supporting surface. Movement of the miter saw on the supporting surface while cutting may result in loss of control and serious personal injury.

1. Fix the base to a level and stable surface, screwing with the bolts. This helps to prevent from tipping and possible injury.

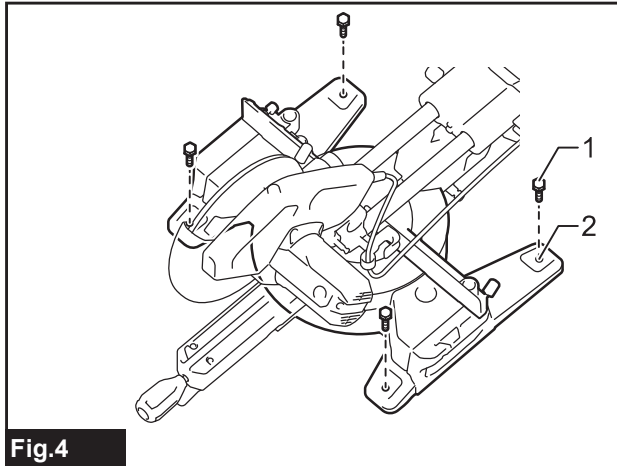

Fig.4

- 1. Bolt 2. Mounting hole

2. Turn the adjusting bolt clockwise or counterclockwise so that it comes into a contact with the floor surface to keep the tool stable.

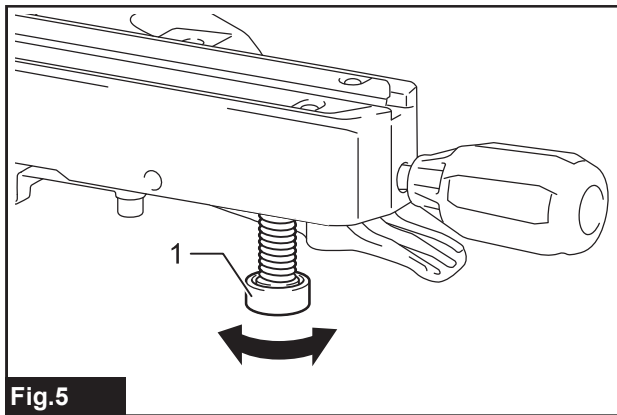

Fig.5

- 1. Adjusting bolt

FUNCTIONAL DESCRIPTION

⚠ WARNING: Always be sure that the tool is switched off and unplugged before adjusting or checking function on the tool. Failure to switch off and unplug the tool may result in serious personal injury from accidental start-up.

Handle lock

⚠ CAUTION: Always hold the handle when releasing the stopper pin. Otherwise the handle springs up and it may result in personal injury.

When the tool is shipped, the handle is locked in the lowered position with the stopper pin. To unlock the handle, pull the stopper pin while lowering the handle slightly.

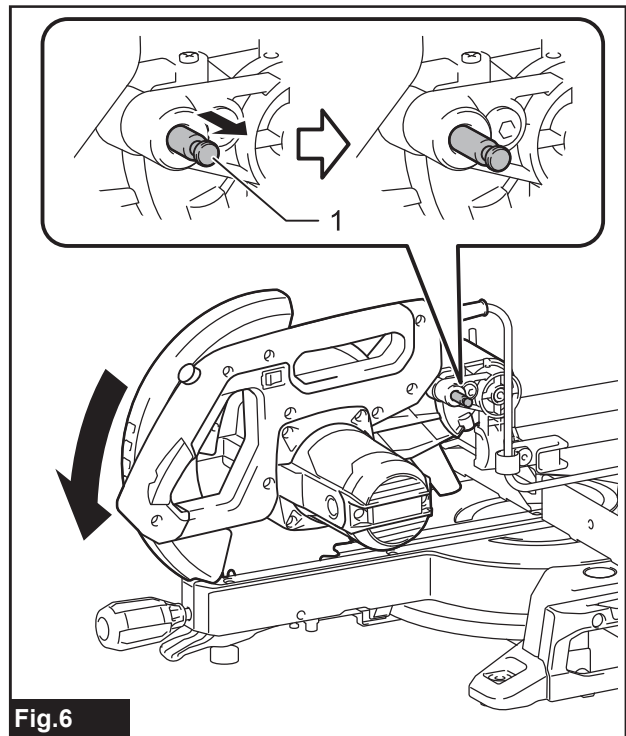

Fig.6

- 1. Stopper pin

Slide lock

To allow the sliding movement of the carriage, loosen thumb screw on the arm. To lock the sliding movement of the carriage, move the carriage to your desired position, and then tighten the thumb screw securely.

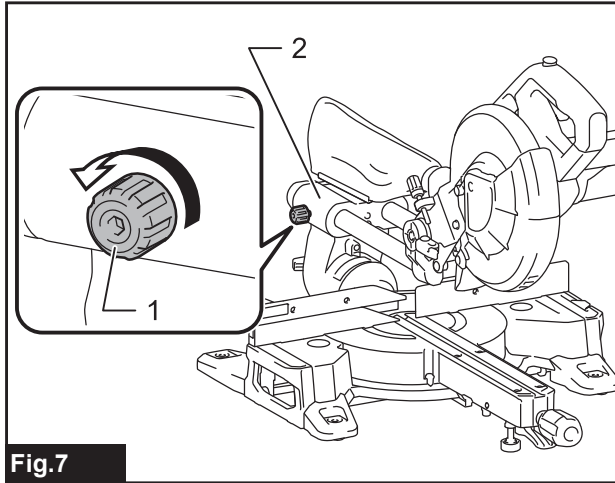

Fig.7

- ▶ 1. Thumb screw 2. Arm

Blade guard

⚠ WARNING: Never defeat or remove the blade guard or the spring which is attached to the guard. An exposed circular saw blade as a result of defeated guarding may result in serious personal injury during operation.

⚠ WARNING: Never use the tool if the blade guard or spring is damaged, faulty or removed. Operation of the tool with a damaged, faulty or removed guard may result in serious personal injury.

⚠ CAUTION: Always maintain the blade guard in good condition for safe operation. Stop the operation immediately if there are any irregularity of the blade guard. Check to assure spring loaded return action of guard.

When lowering the handle, the blade guard raises automatically. The guard is spring loaded so it returns to its original position when the cut is completed and the handle is raised.

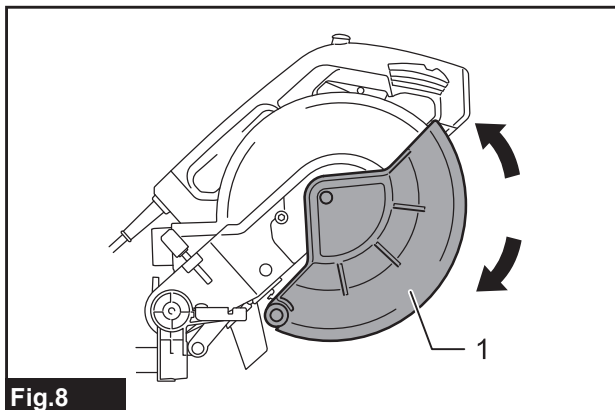

Fig.8

- ▶ 1. Blade guard

Cleaning

If the transparent blade guard becomes dirty, or sawdust adheres to the transparent blade guard in such a way that the circular saw blade and/or workpiece is no longer easily visible, unplug the tool and clean the guard carefully with a damp cloth. Do not use solvents or any petroleum-based cleaners on the plastic guard because this may cause damage to the guard. Follow the step-by-step instructions listed on how to prepare for cleaning.

1. Make sure that the tool is switched off and unplugged.
2. Turn the hex socket bolt counterclockwise using the supplied hex wrench with holding the center cover.
3. Raise the blade guard and center cover.
4. When cleaning is complete, return the center cover and tighten the hex socket bolt by performing the steps above in reverse.

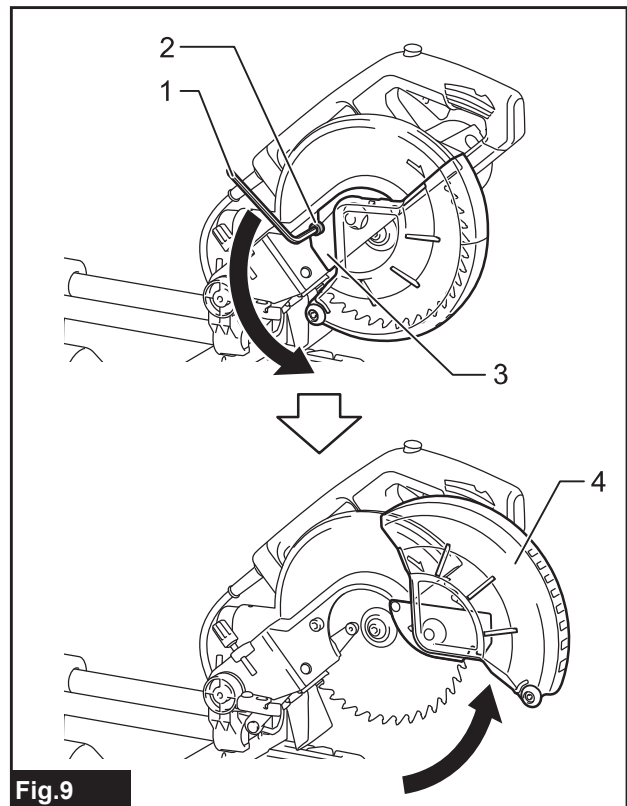

Fig.9

- ▶ 1. Hex wrench 2. Hex socket bolt 3. Center cover 4. Blade guard

⚠ WARNING: Do not remove spring holding blade guard. If guard becomes damaged in course of time or UV light exposure, contact a Makita service center for replacement. **DO NOT DEFEAT OR REMOVE GUARD.**

Positioning kerf boards

This tool is provided with the kerf boards in the turn base to minimize tearing on the exit side of a cut. The kerf boards are factory adjusted so that the circular saw blade does not contact the kerf boards. Before use, adjust the kerf boards as follows:

1. Make sure that the tool is unplugged. Then, loosen all the screws (three each on left and right) securing the kerf boards.

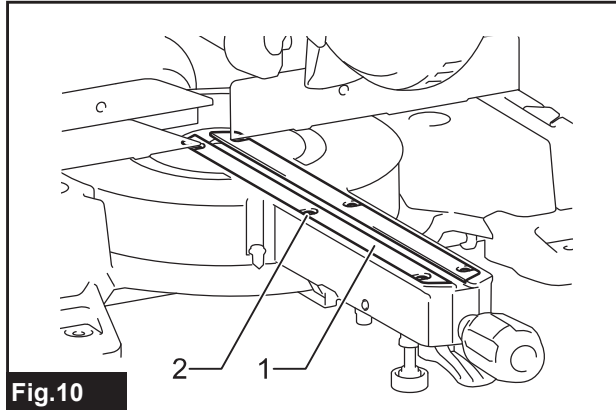

Fig.10

- 1. Kerf board 2. Screw

2. Re-tighten them only to the extent that the kerf boards can still be easily moved by hand.
3. Lower the handle fully, then lock the handle in the lowered position with the stopper pin.
4. Loosen thumb screw on the arm which secures the sliding movement of the carriage.

Pull the carriage toward you fully.

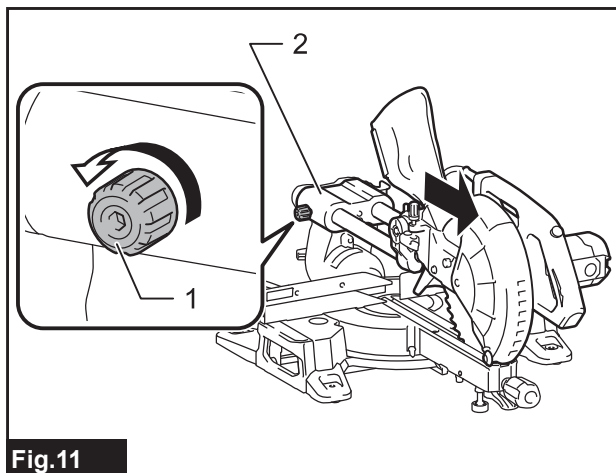

Fig.11

- 1. Thumb screw 2. Arm

5. Adjust the kerf boards so that they are close to the sides of the saw blade teeth.

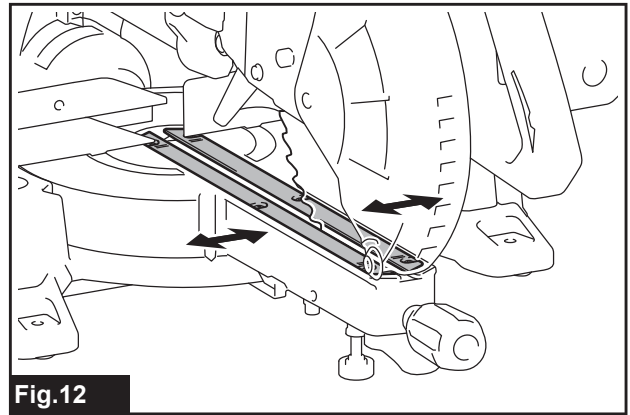

Fig.12

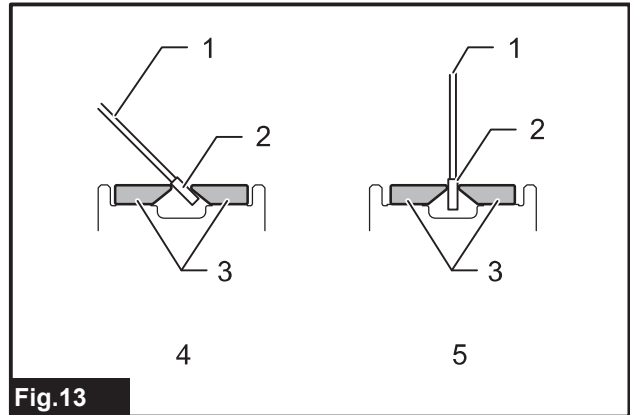

Fig.13

- 1. Circular saw blade 2. Blade teeth 3. Kerf board 4. Left bevel cut 5. Straight cut

6. Tighten the front screws (do not tighten firmly).
7. Slide the carriage to the position between the front end of the kerf boards and guide fences. Adjust the kerf boards so that they are close to the sides of the saw blade teeth.
8. Tighten the center screws (do not tighten firmly).
9. Push the carriage toward the guide fences fully and then adjust the kerf boards so that they are close to the sides of the saw blade teeth.
10. Tighten the rear screws (do not tighten firmly).
11. Release the stopper pin for handle lock and raise the handle. Then tighten all the screws securely.

NOTICE: After setting the bevel angle, ensure that the kerf boards are adjusted properly. Correct adjustment of the kerf boards helps to provide proper support of the workpiece and minimizing workpiece tear out.

Maintaining maximum cutting capacity

This tool is factory adjusted to provide the maximum cutting capacity for a 260 mm circular saw blade. When installing a new circular saw blade, always check the lower limit position of the circular saw blade, and if necessary, adjust it as follows:

1. Unplug the tool. Then, push the carriage toward the guide fence fully and lower the handle completely.
2. Use the hex wrench (screwdriver side) to turn the adjusting bolt until the circular saw blade comes slightly below the cross section of the guide fence and the top surface of the turn base.

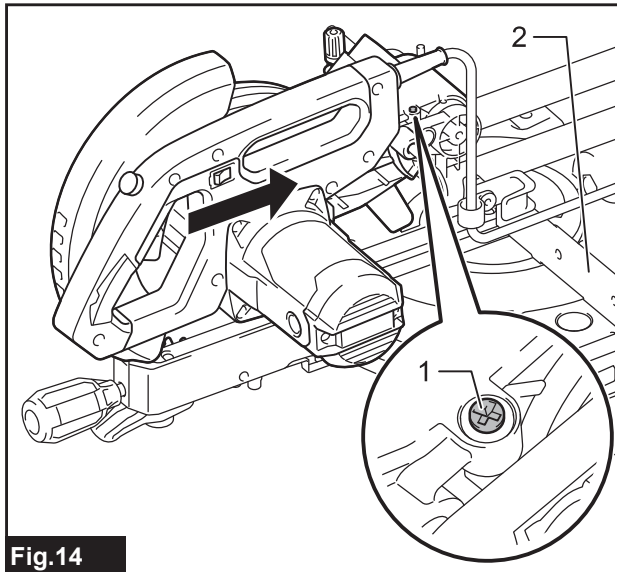

Fig.14

- 1. Adjusting bolt 2. Guide fence

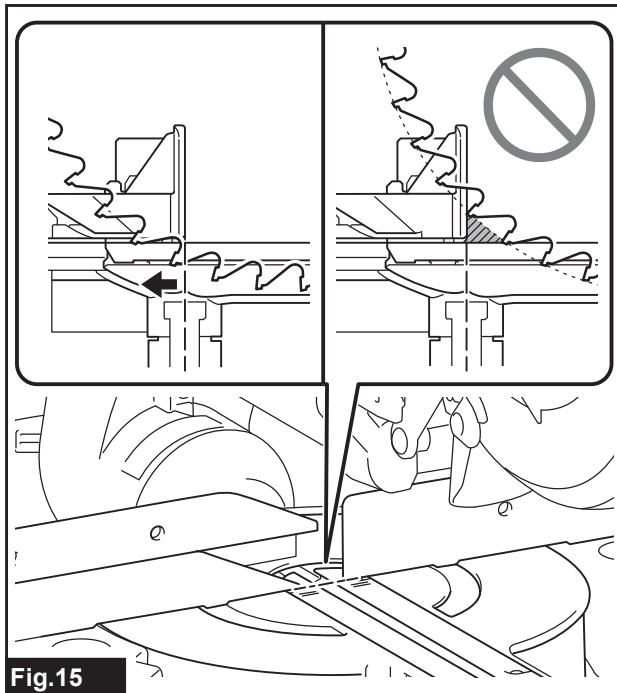

Fig.15

3. Rotate the circular saw blade by hand while holding the handle all the way down to be sure that the circular saw blade does not contact any part of the lower base. Re-adjust the maximum cutting capacity, if necessary.

⚠ WARNING: After installing a new circular saw blade and with the tool is unplugged, always be sure that the circular saw blade does not contact any part of the lower base when the handle is lowered completely. If the circular saw blade contacts with the base, it may cause kickback and result in serious personal injury.

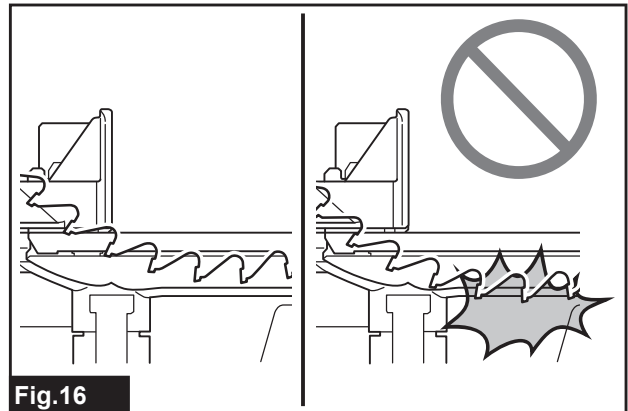

Fig.16

Stopper arm

The lower limit position of the saw blade can be easily adjusted with the stopper arm. To adjust the lower limit, turn the stopper arm in the direction of the arrow as shown in the figure. Turn the adjusting screw so that the saw blade stops at the desired position when lowering the handle fully.

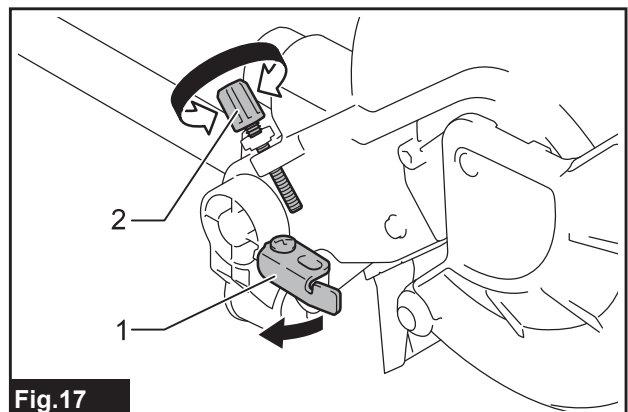

Fig.17

- 1. Stopper arm 2. Adjusting screw

Adjusting the miter angle

CAUTION: After changing the miter angle, always secure the turn base by tightening the grip firmly.

NOTICE: When turning the turn base, be sure to raise the handle fully.

Rotate the grip counterclockwise to unlock the turn base. Turn the grip while holding up the lock lever to move the turn base. Align the pointer with your desired angle in the miter angle scale then tighten the grip.

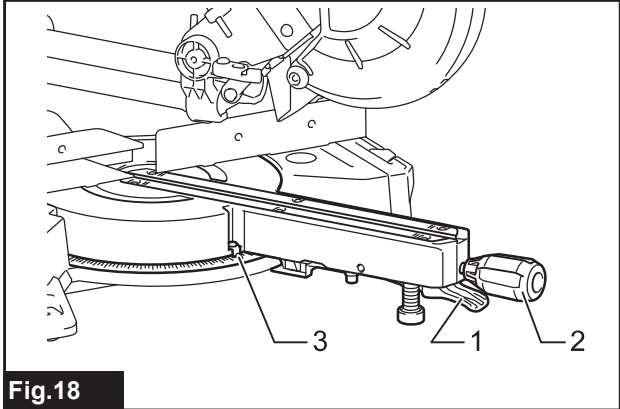

Fig.18

► 1. Lock lever 2. Grip 3. Pointer

Positive stop function

This miter saw employs positive stop function. You can set 0°, 15°, 22.5°, 31.6°, and 45° right/left miter angle quickly. To use this function, move the turn base close to your desired positive stop angle while holding up the lock lever. Then release the lock lever and move the turn base to your desired positive stop angle until the turn base is locked.

Adjusting the bevel angle

CAUTION: After changing the bevel angle, always secure the arm by tightening the lever clockwise.

NOTICE: Always remove vertical vise before adjusting the bevel angle.
NOTICE: When tilting the circular saw blade, be sure that the carriage is fully raised.
NOTICE: When changing bevel angles, be sure to reposition the kerf boards appropriately as explained in the section for positioning kerf boards.
NOTICE: Do not tighten the lever too hard. Doing so may cause malfunction of the locking mechanism of the bevel angle.

Tilting the circular saw blade to the left 0° - 45°

1. Rotate the lever counterclockwise.
2. Hold the handle and tilt the carriage to the left.
3. Align the pointer with your desired angle in the bevel angle scale.
4. Tighten the lever clockwise to secure the arm.

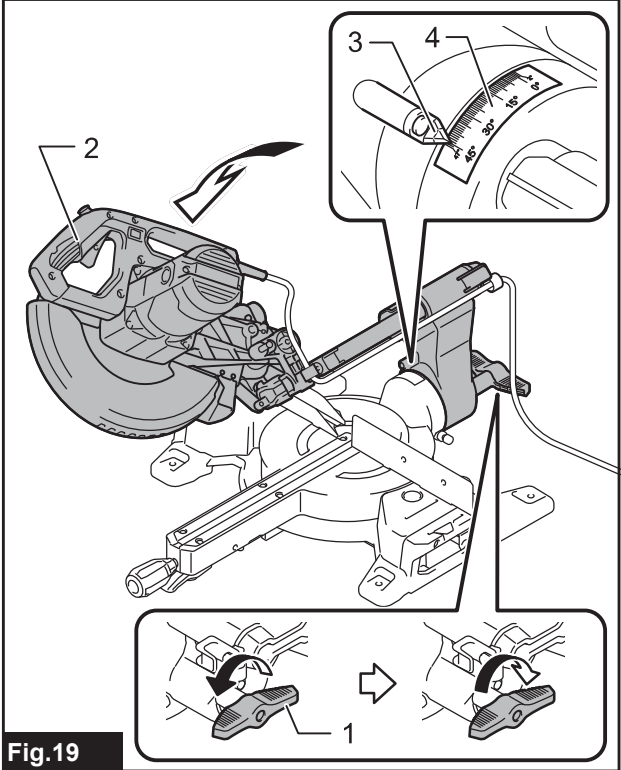

Fig.19

► 1. Lever 2. Handle 3. Pointer 4. Bevel angle scale

Tilting the circular saw blade beyond the left 0° - 45°

1. Rotate the lever counterclockwise.
2. Hold the handle and set the carriage at 0° for right 2° side, or 45° for left 47° side.
3. Tilt the carriage slightly to opposite side.
4. Push the releasing button.
5. Tilt the carriage to the desired position beyond the range 0° - 45°.
6. Tighten the lever clockwise to secure the arm.

When tilting the carriage to the right 2°

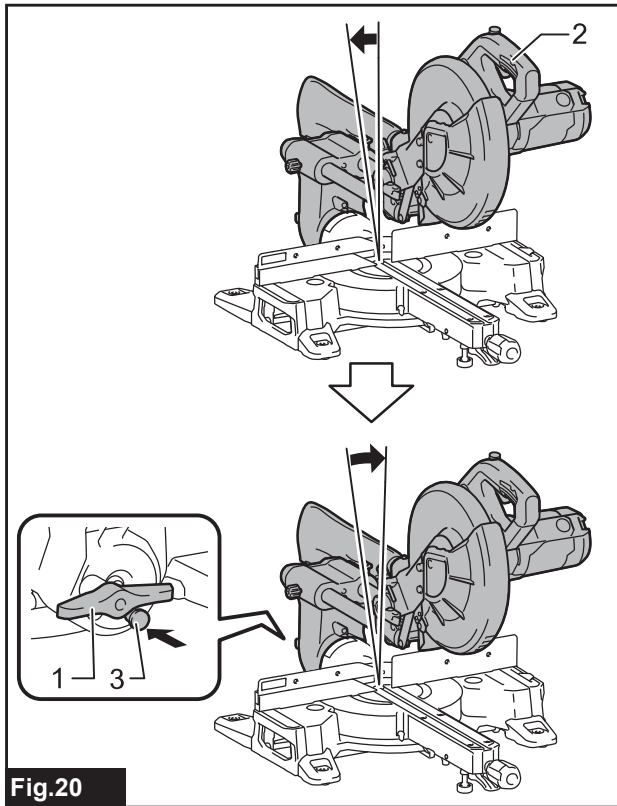

Fig.20

- ▶ 1. Lever 2. Handle 3. Releasing button

When tilting the carriage to the left 47°

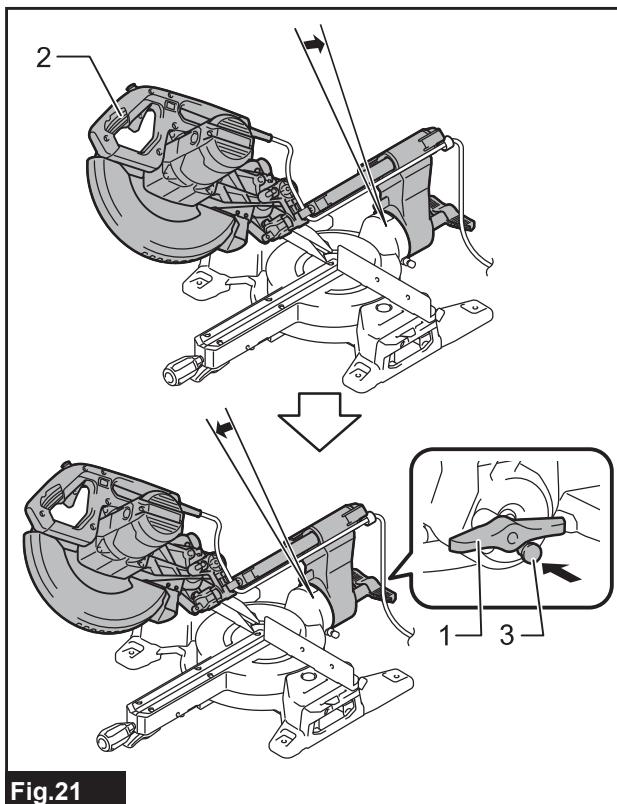

Fig.21

- ▶ 1. Lever 2. Handle 3. Releasing button

Switch action

⚠ WARNING: Before plugging in the tool, always check to see that the switch trigger actuates properly and returns to the “OFF” position when released. Do not pull the switch trigger hard without pressing in the lock-off button. This can cause switch breakage. Operating a tool with a switch that does not actuate properly can lead to loss of control and serious personal injury.

⚠ WARNING: NEVER use tool without a fully operative switch trigger. Any tool with an inoperative switch is HIGHLY DANGEROUS and must be repaired before further usage or serious personal injury may occur.

⚠ WARNING: NEVER defeat the lock-off button by taping down or some other means. A switch with a negated lock-off button may result in unintentional operation and serious personal injury.

⚠ WARNING: NEVER use the tool if it runs when you simply pull the switch trigger without pressing the lock-off button. A switch in need of repair may result in unintentional operation and serious personal injury. Return tool to a Makita service center for proper repairs BEFORE further usage.

To prevent the switch trigger from being accidentally pulled, a lock-off button is provided. To start the tool, press in the lock-off button and pull the switch trigger. Release the switch trigger to stop.

A hole is provided in the switch trigger for insertion of a padlock to lock the tool off.

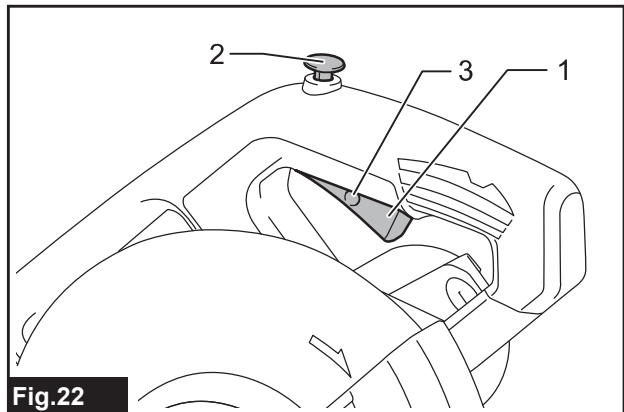

Fig.22

- ▶ 1. Switch trigger 2. Lock-off button 3. Hole for padlock

⚠ WARNING: Do not use a lock with a shank or cable any smaller than 6.35 mm in diameter. A smaller shank or cable may not properly lock the tool in the off position and unintentional operation may occur resulting in serious personal injury.

Casting a cutting line

CAUTION: The lamp is not a rainproof. Do not wash the lamp in water or use it in a rain or a wet area. Such a conduct can cause an electric shock and fume.

CAUTION: Do not touch the lens of the lamp as it is very hot while it is lighted or shortly after it is turned off. This may cause burns.

CAUTION: Do not apply impact to the lamp, which may cause damage or shortened service time to it.

CAUTION: Do not look in the light or see the source of light directly.

The LED lamp casts a light over the circular saw blade, and a shadow of the saw blade falls onto a workpiece serving as a calibration-free cutting line indicator. Press the lamp switch to shed a light. A line appears in which the saw blade will meet the surface of the workpiece, becoming deepened as the saw blade gets lowered.

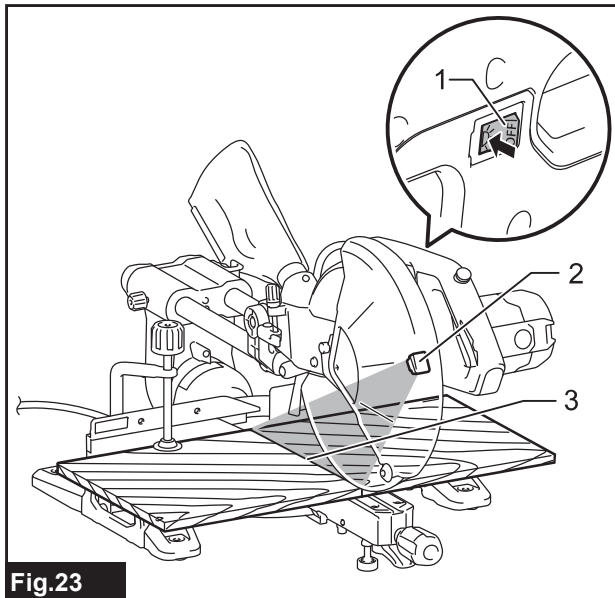

Fig.23

- 1. Lamp switch 2. Lamp 3. Cutting line

The indicator helps cut through an existing cut-off line penciled on a workpiece.

1. Hold the handle and lower the circular saw blade so a dense shadow of the saw blade is thrown against a workpiece.
2. Align a cut-off line drawn on the workpiece with the shadowed cutting line.
3. Adjust the miter angles and bevel angles if necessary.

NOTE: Be sure to turn off the lamp switch after use. Otherwise the lamp stays hot.

Electronic function

Soft start feature

This function allows the smooth start-up of the tool by limiting the start-up torque.

ASSEMBLY

WARNING: Always be sure that the tool is switched off and unplugged before working on the tool. Failure to switch off and unplug the tool may result in serious personal injury.

Hex wrench storage

When not in use, store the hex wrench as shown in the figure to keep it from being lost.

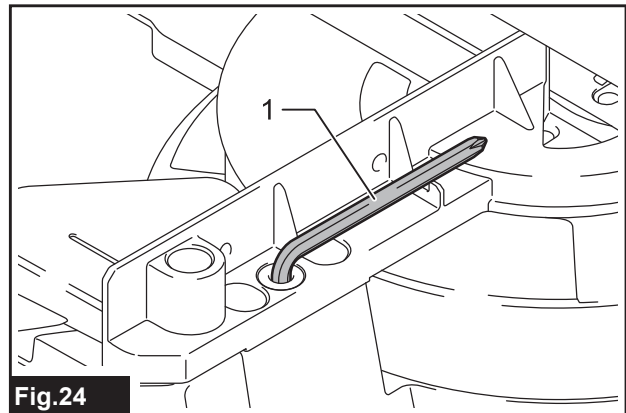

Fig.24

- 1. Hex wrench

Installing or removing circular saw blade

WARNING: Always be sure that the tool is switched off and unplugged before removing and installing the circular saw blade. Accidental startup of the tool may result in serious personal injury.

WARNING: Use only the Makita wrench provided to remove and install the circular saw blade. Failure to use the wrench may result in overtightening or insufficient tightening of the hex socket bolt and serious personal injury.

WARNING: Never use or substitute the parts which are not supplied with this tool. Using such parts can cause serious personal injury.

WARNING: After installing the circular saw blade, always make sure that it is securely installed. Loose attachment of the circular saw blade can cause serious personal injury.

Common preparations for installing or removing the circular saw blade

1. Unlock the carriage by pulling the stopper pin, then move the carriage to the raised position.
2. Loosen the hex socket bolt holding the center cover using the hex wrench. Then, raise the blade guard and center cover.

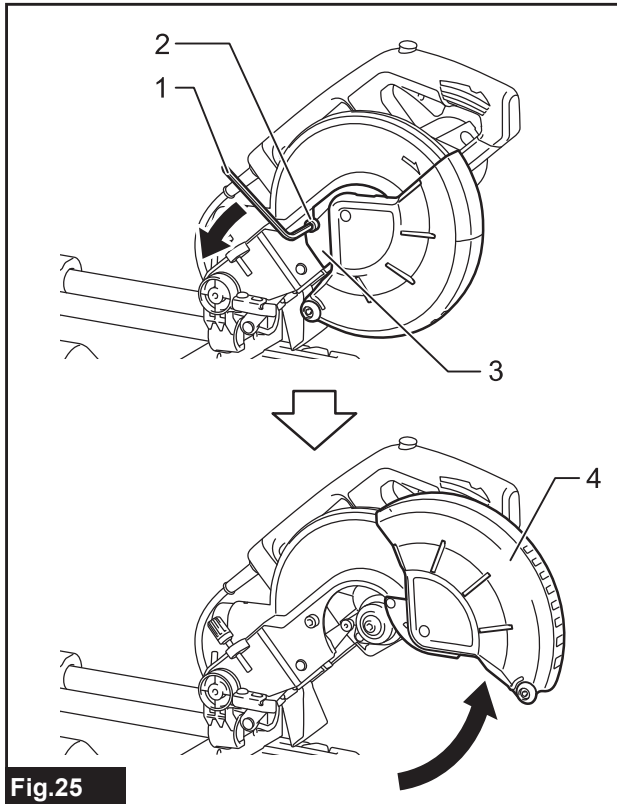

Fig.25

- ▶ 1. Hex wrench 2. Hex socket bolt 3. Center cover 4. Blade guard

Installing the circular saw blade

CAUTION: Make sure to install the circular saw blade so that the direction of the arrow on the circular saw blade matches that on the blade case. Failure to do so may result in personal injury and cause damage to the tool and/or the workpiece.

1. Complete the steps in the “Common preparations for installing or removing the circular saw blade”.
2. Press the shaft lock to lock the spindle and use the hex wrench to loosen the hex socket bolt clockwise. Then remove the hex socket bolt and outer flange.

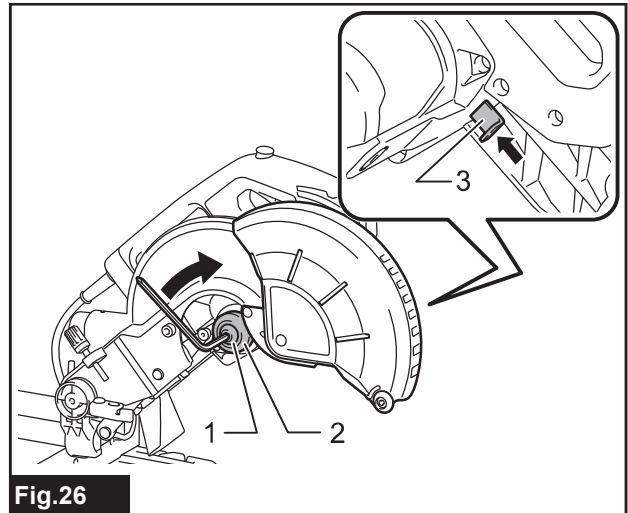

Fig.26

- ▶ 1. Hex socket bolt (left-handed) 2. Outer flange 3. Shaft lock

3. Mount the circular saw blade carefully onto the inner flange. Make sure that the direction of the arrow on the circular saw blade matches the direction of the arrow on the blade case.

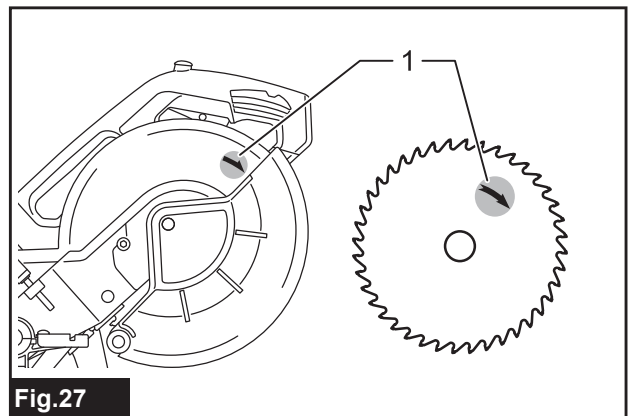

Fig.27

- ▶ 1. Arrow

4. Install the outer flange and hex socket bolt. Tighten the hex socket bolt (left-handed) counterclockwise securely using the hex wrench while pressing the shaft lock.

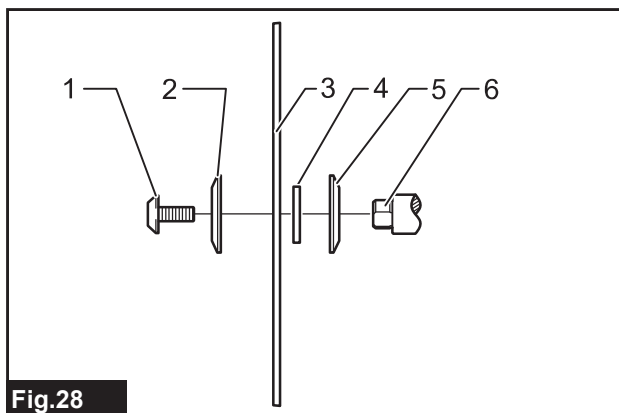

Fig.28

- ▶ 1. Hex socket bolt (left-handed) 2. Outer flange
- 3. Circular saw blade 4. Ring 5. Inner flange
- 6. Spindle

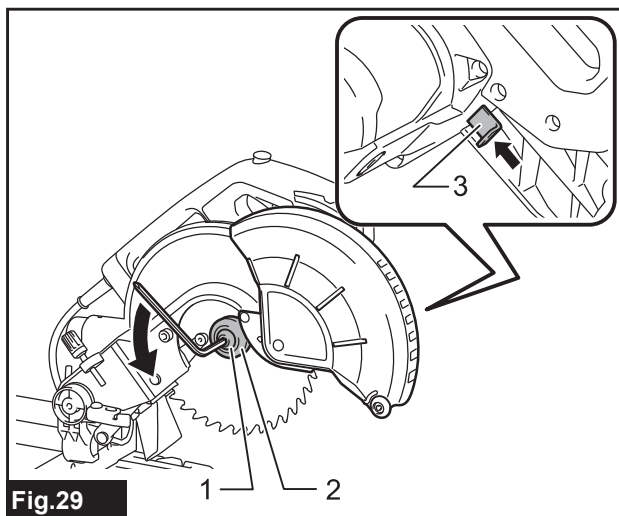

Fig.29

- ▶ 1. Hex socket bolt (left-handed) 2. Outer flange
- 3. Shaft lock

5. Return the blade guard and center cover to its original position. Then tighten the hex socket bolt of the center cover to secure it.

Lower the carriage and check that the blade guard moves properly.

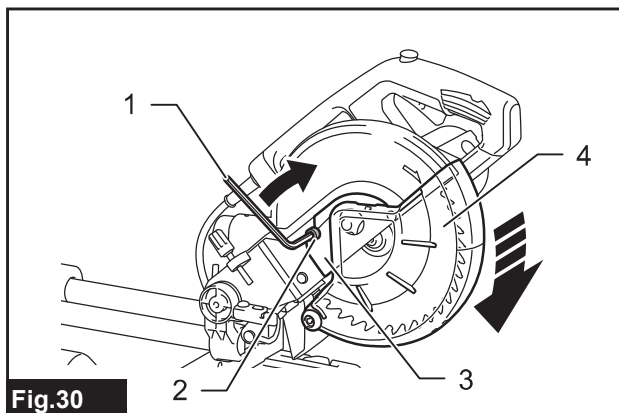

Fig.30

- ▶ 1. Hex wrench 2. Hex socket bolt 3. Center cover
- 4. Blade guard

Removing the circular saw blade

1. Complete the steps in the "Common preparations for installing or removing the circular saw blade".
2. Press the shaft lock to lock the spindle. Loosen the hex socket bolt clockwise using the hex wrench. Then remove the hex socket bolt, outer flange and circular saw blade.

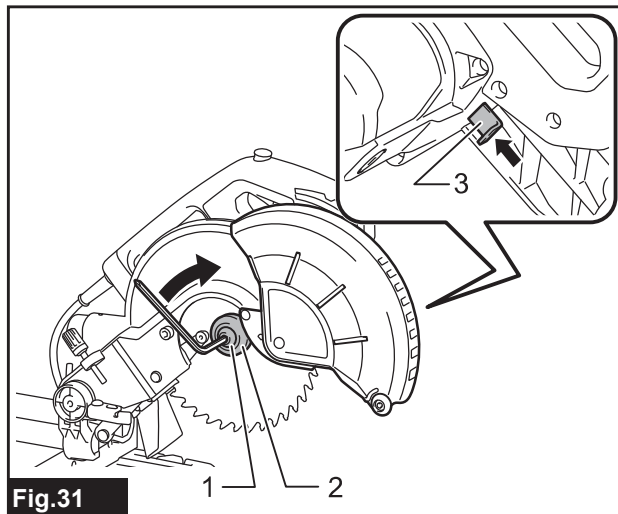

Fig.31

- ▶ 1. Hex socket bolt (left-handed) 2. Outer flange
- 3. Shaft lock

3. If the inner flange is removed, install it on the spindle with its blade mounting part facing the circular saw blade. If the flange is installed incorrectly, the flange will rub against the machine.

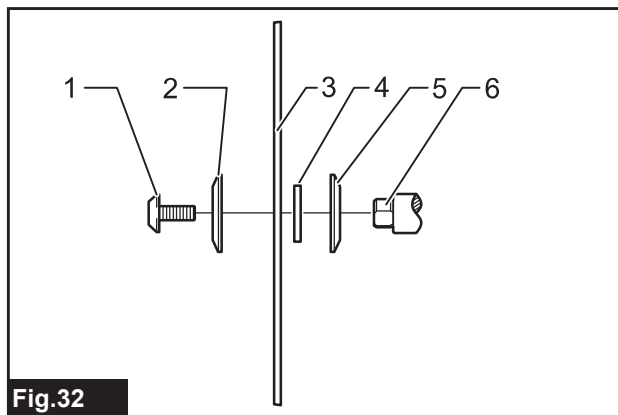

Fig.32

- ▶ 1. Hex socket bolt (left-handed) 2. Outer flange
- 3. Circular saw blade 4. Ring 5. Inner flange
- 6. Spindle

NOTICE: Be careful not to lose the removed outer flange and hex socket bolt.

Connecting a vacuum cleaner

When you wish to perform clean cutting operation, connect a Makita vacuum cleaner.

NOTICE: Depending on the type of vacuum cleaner and hose used, the dust collecting port may be blocked by the dust collecting guard, making it impossible to collect dust. In that case, weaken the suction power of the vacuum cleaner.

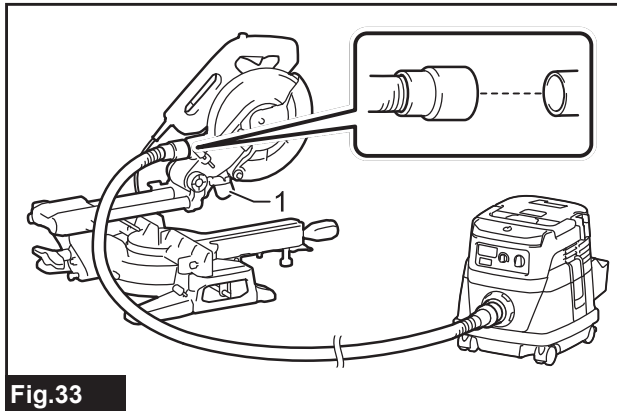

Fig.33

► 1. Dust collecting guard

Dust bag

CAUTION: When performing a cutting, always attach the dust bag or connect a vacuum cleaner to prevent dust-related hazards.

The use of the dust bag makes cutting operations clean and dust collection easy. To attach the dust bag, connect the dust bag to the dust nozzle.

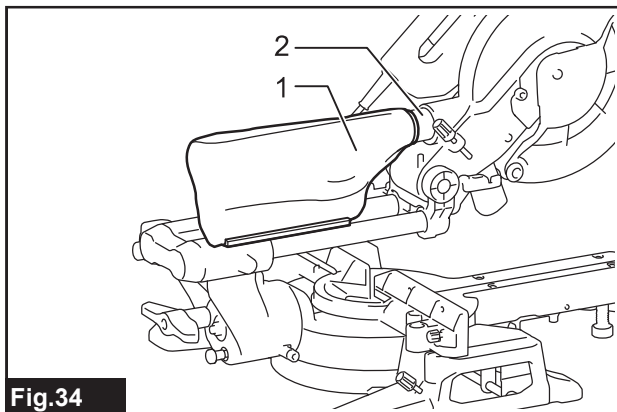

Fig.34

► 1. Dust bag 2. Dust nozzle

When the dust bag is about half full, remove the dust bag from the tool and pull the fastener out. Empty the dust bag of its contents, tapping it lightly so as to remove particles adhering to the insides which might hamper further collection.

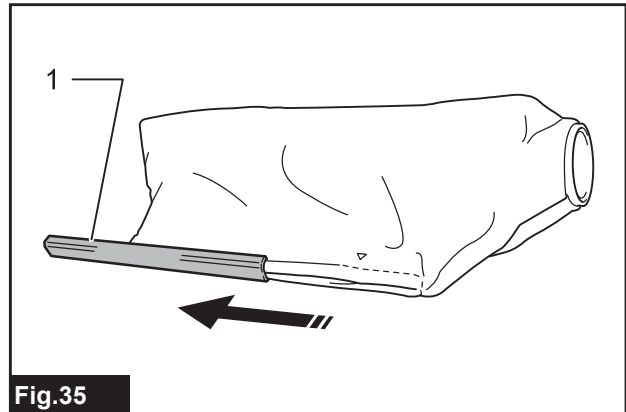

Fig.35

► 1. Fastener

Securing workpiece

WARNING: It is extremely important to always secure the workpiece correctly with the proper type of vise. Failure to do so may result in serious personal injury and cause damage to the tool and/or the workpiece.

WARNING: After a cutting operation, do not raise the saw blade until it has come to a complete stop. The raising of a coasting saw blade may result in serious personal injury and damage to the workpiece.

WARNING: When cutting a workpiece that is longer than the support base of the miter saw, the material should be supported the entire length beyond the support base and at the same height to keep the material level. Proper workpiece support will help avoid blade pinch and possible kickback which may result in serious personal injury. Do not rely solely on the vertical vise to secure the workpiece. Thin material tends to sag. Support workpiece over its entire length to avoid blade pinch and possible KICKBACK.

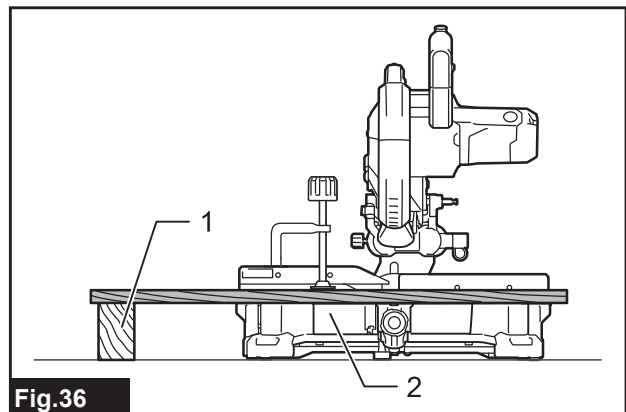

Fig.36

► 1. Support 2. Turn base

Guide fences

⚠WARNING: Before operating the tool, make sure that the sliding fence is secured with the clamping screw firmly.

⚠WARNING: Before bevel-cutting, make sure that no part of the tool, especially the circular saw blade, contacts the fences when fully lowering and raising the handle in any position and while moving the carriage through its full range of travel. If the tool or circular saw blade makes contact with the fence, this may result in kickback or unexpected movement of the material and serious personal injury.

This tool is equipped with the sliding fence. When performing left bevel cuts, loosen the clamping screw and move the sliding fence so that it does not hinder the carriage movement. Secure the sliding fence by tightening the clamping screw.

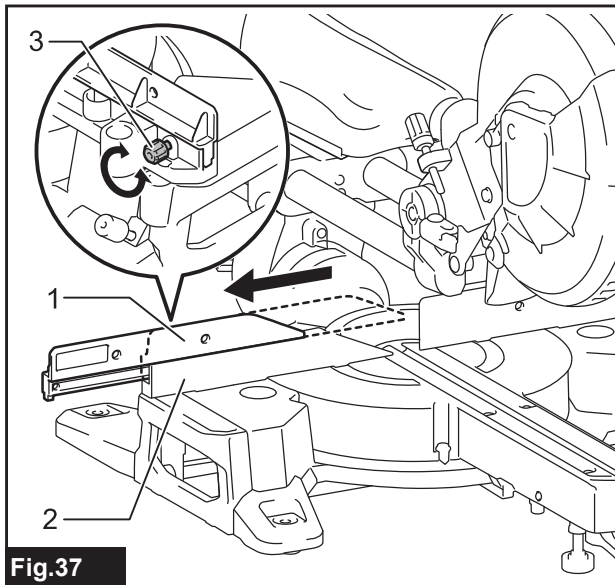

Fig.37

► 1. Sliding fence 2. Guide fence 3. Clamping screw

Vertical vise

⚠WARNING: The workpiece must be secured firmly against the turn base and guide fence with the vise during all operations. If the workpiece is not properly secured against the fence, the material may move during the cutting operation causing possible damage to the saw blade, causing the material to be thrown and loss of control resulting in serious personal injury.

The vertical vise can be installed into the holes on the left side of the base, right side of the base, or left side of the sub base.

Press the workpiece flat against the guide fence and the turn base. Position the workpiece at the desired cutting position and secure it firmly by tightening the vise knob. Make sure that no part of the tool contacts the vertical vise when lowering the handle all the way. If some part contacts the vertical vise, re-position the vertical vise.

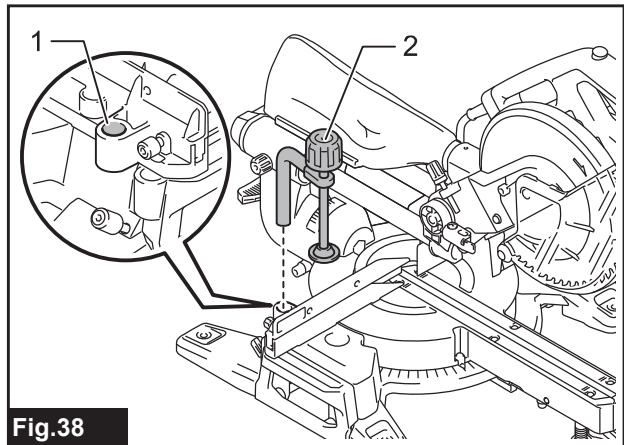

Fig.38

► 1. Hole 2. Vise knob

Sub base

⚠WARNING: Always support a long workpiece so it is level with the top surface of the turn base for an accurate cut and to prevent dangerous loss of tool control. Proper workpiece support will help avoid blade pinch and possible kickback which may result in serious personal injury.

⚠WARNING: Before the cutting operation, always be sure that the sub bases are secured by the thumb screws.

To hold long workpieces horizontally, sub bases are provided on both sides of the tool. Loosen the thumb screws and extend the sub bases to the appropriate length for holding the workpiece. Then tighten the thumb screws.

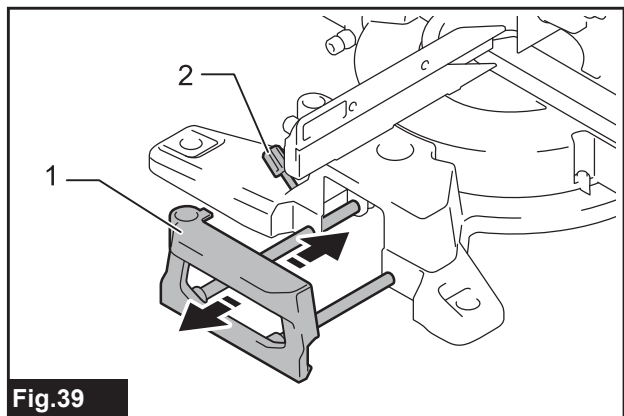

Fig.39

► 1. Sub base 2. Thumb screw

When cutting, place the workpiece flat against the guide fences.

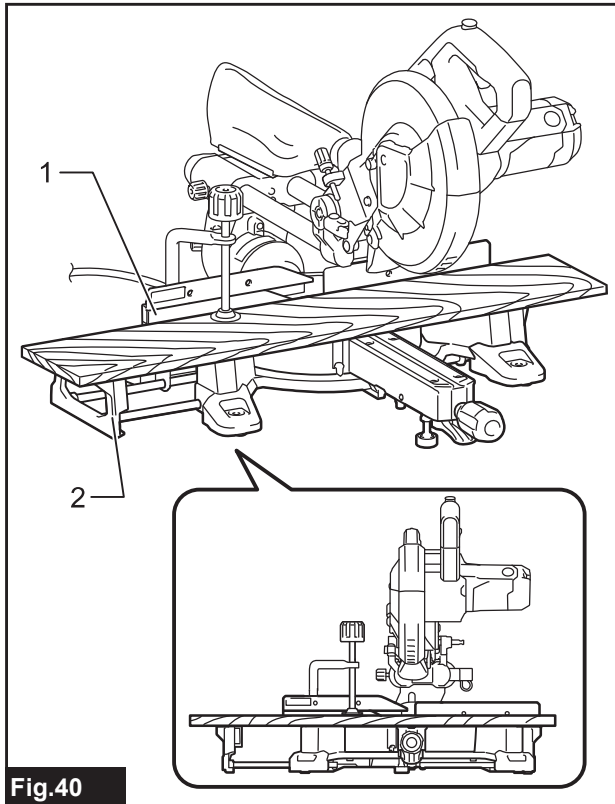

Fig.40

► 1. Guide fence 2. Sub base

OPERATION

This tool is intended to cut wood products. With appropriate Makita genuine saw blades, following materials can also be sawed :

— Aluminum products

Refer to our website or contact your local Makita dealer for the correct circular saw blades to be used for the material to be cut.

⚠ WARNING: Make sure the saw blade is not contacting the workpiece, etc. before the switch is turned on. Turning the tool on with the saw blade in contact with the workpiece may result in kickback and serious personal injury.

⚠ WARNING: After a cutting operation, do not raise the saw blade until it has come to a complete stop. The raising of a coasting saw blade may result in serious personal injury and damage to the workpiece.

⚠ WARNING: Do not perform any adjustment such as turning grip, knob, and levers on the tool while the saw blade is rotating. Adjustment while the saw blade is rotating may result in serious personal injury.

⚠ CAUTION: Do not release the saw head uncontrolled from the fully down position. Uncontrolled saw head may hit you and it will result in personal injury.

NOTICE: Before use, be sure to unlock the stopper pin and release the handle from the lowered position.

NOTICE: Do not apply excessive pressure on the handle when cutting. Too much force may result in overload of the motor and/or decreased cutting efficiency. Press down handle with only as much force as necessary for smooth cutting and without significant decrease in blade speed.

NOTICE: Gently press down the handle to perform the cut. If the handle is pressed down with force or if lateral force is applied, the saw blade may vibrate and leave a mark (saw mark) in the workpiece and the precision of the cut may be impaired.

NOTICE: During a slide cut, gently push the carriage toward the guide fence without stopping. If the carriage movement is stopped during the cut, a mark will be left in the workpiece and the precision of the cut will be impaired.

Press cutting

⚠ WARNING: Always lock the sliding movement of the carriage when performing a press cutting. Cutting without lock may cause possible kickback which may result in serious personal injury.

Workpieces up to 91 mm high and 90 mm wide can be cut in the following manner.

1. Push the carriage toward the guide fence until it stops and lock it with the thumb screw.
2. Secure the workpiece with the proper type of vise.
3. Switch on the tool without the circular saw blade making any contact and wait until the circular saw blade attains full speed before lowering.
4. Gently lower the handle to the fully lowered position to cut the workpiece.
5. When the cut is completed, switch off the tool and wait until the circular saw blade has come to a complete stop before returning the circular saw blade to its fully elevated position.

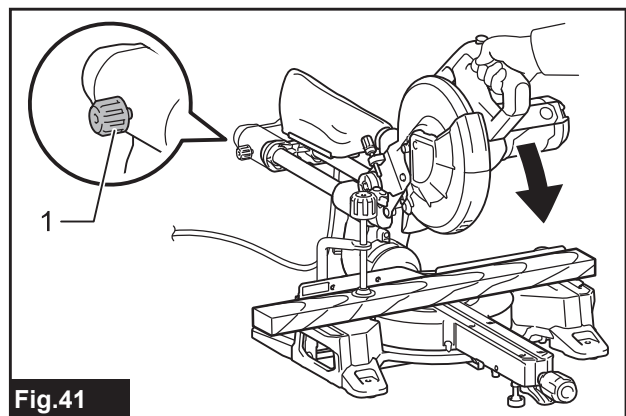

Fig.41

► 1. Thumb screw

Slide (push) cutting (cutting wide workpieces)

⚠ WARNING: Whenever performing a slide cut, first pull the carriage full towards you and press the handle all the way down, then push the carriage toward the guide fence. Never start the cut with the carriage not pulled fully toward you. If you perform the slide cut without the carriage pulled fully toward you, unexpected kickback may occur and serious personal injury may result.

⚠ WARNING: Never attempt to perform a slide cut by pulling the carriage towards you. Pulling the carriage towards you while cutting may cause unexpected kickback resulting in possible serious personal injury.

⚠ WARNING: Never perform the slide cut with the handle locked in the lowered position.

1. Loosen the thumb screw so that the carriage can slide freely.
2. Secure the workpiece with the proper type of vise.
3. Pull the carriage toward you fully.
4. Switch on the tool without the circular saw blade making any contact and wait until the saw blade attains full speed.
5. Press the handle down and **push the carriage toward the guide fence and through the workpiece.**
6. When the cut is completed, switch off the tool and **wait until the saw blade has come to a complete stop** before returning the saw blade to its fully elevated position.

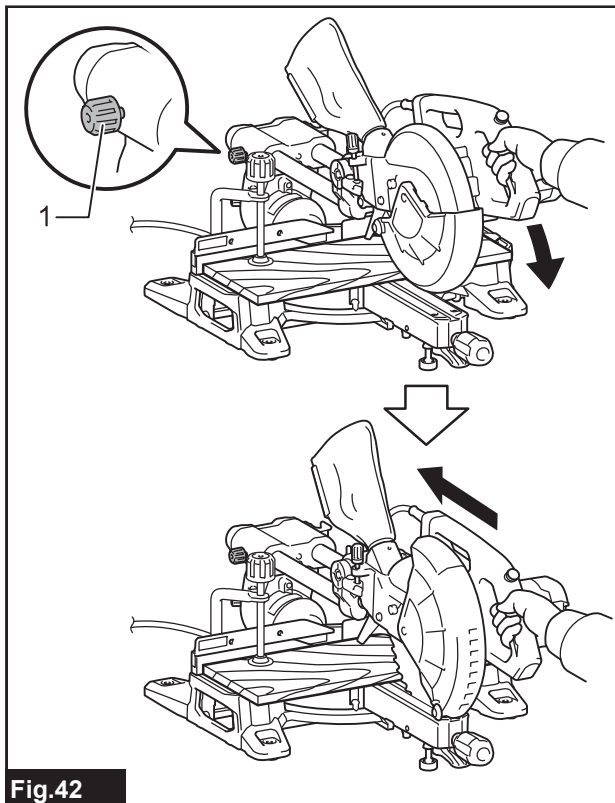

Fig.42

- 1. Thumb screw

Miter cutting

Refer to the section for adjusting the miter angle.

Bevel cut

⚠ WARNING: After setting the saw blade for a bevel cut, ensure that the carriage and saw blade will have free travel throughout the entire range of the intended cut before operating the tool.

Interruption of the carriage or blade travel during the cutting operation may result in kickback and serious personal injury.

⚠ WARNING: While making a bevel cut, keep hands out of the path of the saw blade. The angle of the saw blade may confuse the operator as to the actual blade path while cutting and contact with the saw blade will result in serious personal injury.

⚠ WARNING: The saw blade should not be raised until it has come to a complete stop. During a bevel cut, the piece cut off may come to rest against the saw blade. If the saw blade is raised while it is rotating, the cut-off piece may be ejected by the saw blade causing the material to fragment which may result in serious personal injury.

NOTICE: When pressing down the handle, apply pressure in parallel with the saw blade. If a force is applied perpendicularly to the turn base or if the pressure direction is changed during a cut, the precision of the cut will be impaired.

1. Set the sliding fence on the left to prevent the carriage from contacting.
2. Unlock the stopper pin and loosen thumb screw on the arm so that the carriage can be elevated and slid freely.
3. Adjust the bevel angle according to the procedure explained in the section for bevel angle adjustment. Then tighten the grip.
4. Secure the workpiece with a vise.
5. Pull the carriage toward you fully.
6. Switch on the tool without the circular saw blade making any contact and wait until the circular saw blade attains full speed.
7. Gently lower the handle to the fully lowered position while applying pressure in parallel with the circular saw blade and **push the carriage toward the guide fence to cut the workpiece.**

8. When the cut is completed, switch off the tool and wait until the circular saw blade has come to a complete stop before returning the saw blade to its fully elevated position.

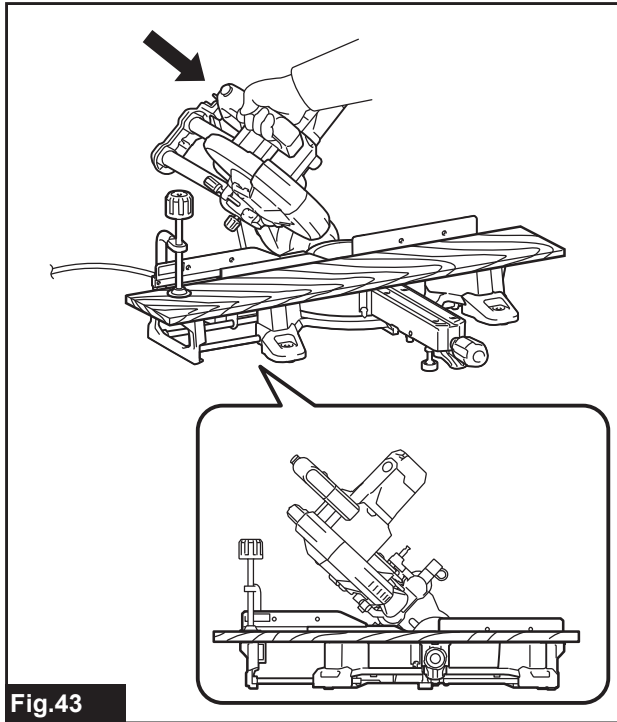

Fig.43

Compound cutting

Compound cutting is the process in which a bevel angle is made at the same time in which a miter angle is being cut on a workpiece. Compound cutting can be performed at the angle shown in the table.

Miter angle	Bevel angle
Left and Right 0° - 45°	Left 0° - 45°

When performing compound cutting, refer to the section for press cutting, slide (push) cutting, miter cutting and bevel cut.

Cutting crown and cove moldings

Crown and cove moldings can be cut on a compound miter saw with the moldings laid flat on the turn base. There are two common types of crown moldings and one type of cove moldings; 52/38° wall angle crown molding, 45° wall angle crown molding and 45° wall angle cove molding.

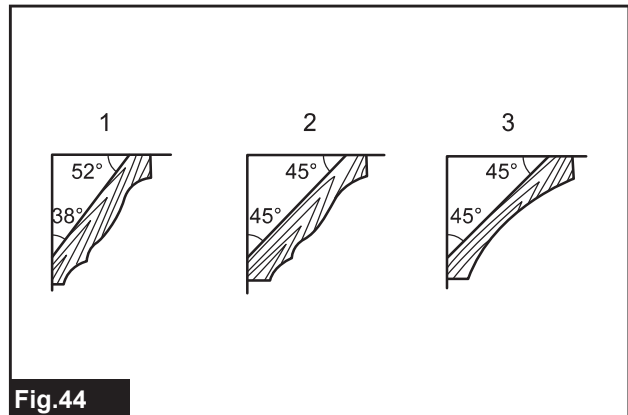
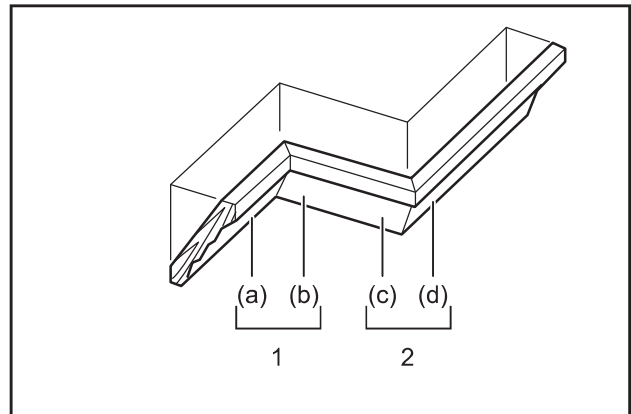

Fig.44

► 1. 52/38° type crown molding 2. 45° type crown molding 3. 45° type cove molding

There are crown and cove molding joints which are made to fit "Inside" 90° corners ((a) and (b) in the figure) and "Outside" 90° corners ((c) and (d) in the figure.)



1. Inside corner 2. Outside corner

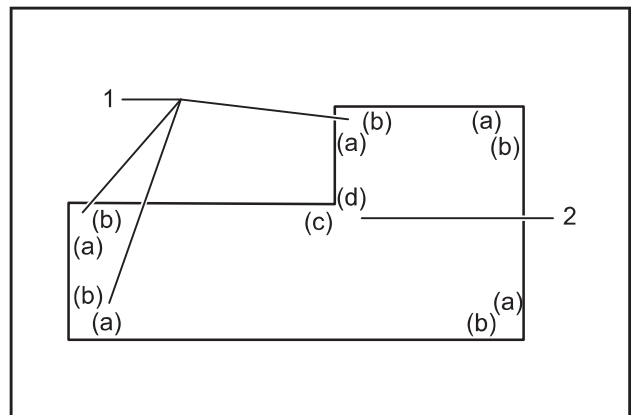

1. Inside corner 2. Outside corner

Measuring

Measure the wall width, and adjust the width of the workpiece according to it. Always make sure that width of the workpiece's wall contact edge is the same as wall length.

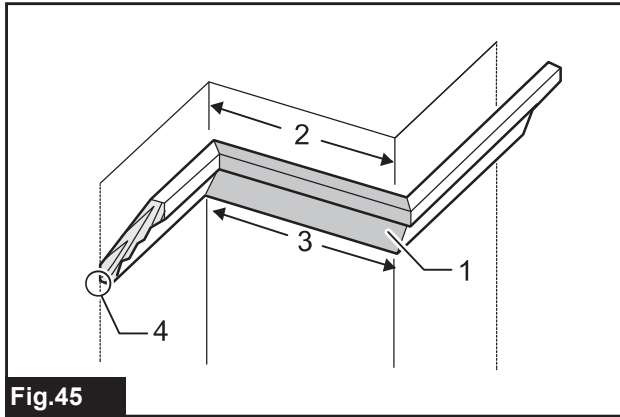

Fig.45

- 1. Workpiece 2. Wall width 3. Width of the workpiece 4. Wall contact edge

Always use several pieces for test cuts to check the saw angles.

When cutting crown and cove moldings, set the bevel angle and miter angle as indicated in the table (A) and position the moldings on the top surface of the saw base as indicated in the table (B).

In the case of left bevel cut

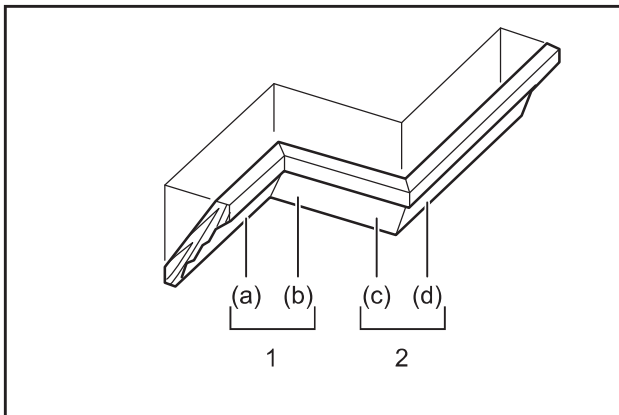

1. Inside corner 2. Outside corner

Table (A)

-	Molding position in the figure	Bevel angle		Miter angle	
		52/38° type	45° type	52/38° type	45° type
For inside corner	(a)	Left 33.9°	Left 30°	Right 31.6°	Right 35.3°
	(b)			Left 31.6°	Left 35.3°
For outside corner	(c)			Right 31.6°	Right 35.3°
	(d)				

Table (B)

-	Molding position in the figure	Molding edge against guide fence	Finished piece
For inside corner	(a)	Ceiling contact edge should be against guide fence.	Finished piece will be on the Left side of the circular saw blade.
	(b)	Wall contact edge should be against guide fence.	
For outside corner	(c)	Wall contact edge should be against guide fence.	Finished piece will be on the Right side of the circular saw blade.
	(d)	Ceiling contact edge should be against guide fence.	

Example:

In the case of cutting 52/38° type crown molding for position (a) in the above figure:

- Tilt and secure bevel angle setting to 33.9° LEFT.
- Adjust and secure miter angle setting to 31.6° RIGHT.
- Lay crown molding with its broad back (hidden) surface down on the turn base with its CEILING CONTACT EDGE against the guide fence on the saw.
- The finished piece to be used will always be on the LEFT side of the circular saw blade after the cut has been made.

Cutting aluminum extrusion

When securing aluminum extrusions, use spacer blocks or pieces of scrap as shown in the figure to prevent deformation of the aluminum. Use a cutting lubricant when cutting the aluminum extrusion to prevent build-up of the aluminum material on the circular saw blade.

⚠ WARNING: Never attempt to cut thick or round aluminum extrusions. Thick or round aluminum extrusions can be difficult to secure and the work may loosen during the cutting operation which may result in loss of control and serious personal injury.

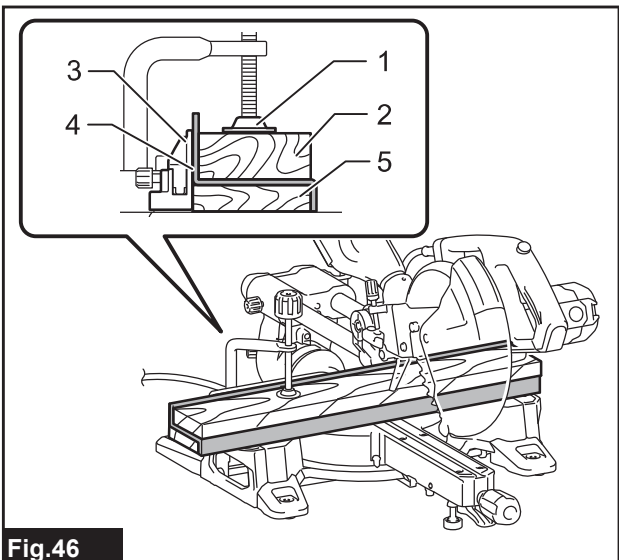

Fig.46

- 1. Vise 2. Spacer block 3. Guide fence 4. Aluminum extrusion 5. Spacer block

Cutting repetitive lengths

When cutting several pieces of stock to the same length, ranging from 225 mm to 350 mm, pull up the set plate as shown in the figure.

Secure the workpiece in the position for cutting. Slide the right sub base so that the set plate flushes against the end of the workpiece. Then secure the sub base with the thumb screw.

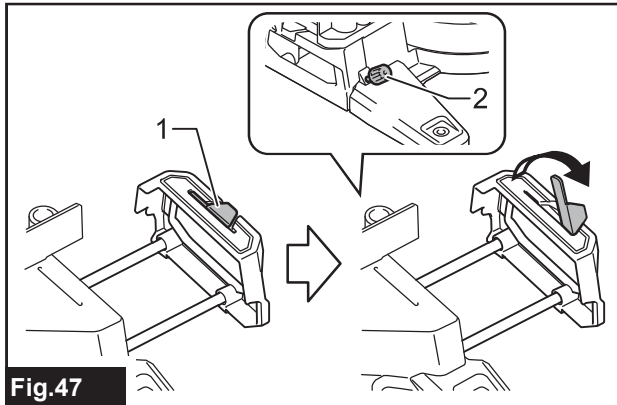

Fig.47

► 1. Set plate 2. Thumb screw

Groove cutting

⚠ WARNING: Do not attempt to perform this type of cut by using a wider type blade or dado blade. Attempting to make a groove cut with a wider blade or dado blade could lead to unexpected cutting results and kickback which may result in serious personal injury.

⚠ WARNING: Be sure to return the stopper arm to the original position when performing other than groove cutting. Attempting to make cuts with the stopper arm in the incorrect position could lead to unexpected cutting results and kickback which may result in serious personal injury.

For a dado type cut, perform as follows:

1. Adjust the lower limit position of the circular saw blade using the adjusting screw and the stopper arm to limit the cutting depth of the circular saw blade. Refer to the section for stopper arm.
2. After adjusting the lower limit position of the circular saw blade, cut parallel grooves across the width of the workpiece using a slide (push) cut.

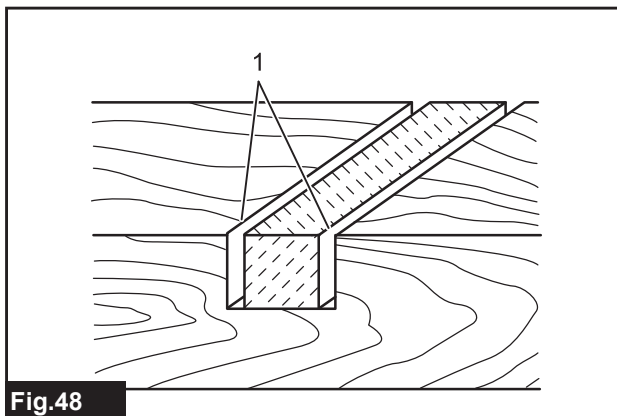

Fig.48

► 1. Cut grooves with saw blade

3. Remove the workpiece material between the grooves with a chisel.

Carrying tool

Before carrying the tool, be sure to unplug the tool and all movable parts of the tool are secured. Always check the following:

- The tool is unplugged.
- The carriage is at 0° bevel angle position and secured.
- The carriage is lowered and locked.
- The carriage is slid toward you fully and locked.
- The turn base is at the full right miter angle position and secured.

Carry the tool by holding the carry handle and one side of the tool base or by holding both sides of the tool base.

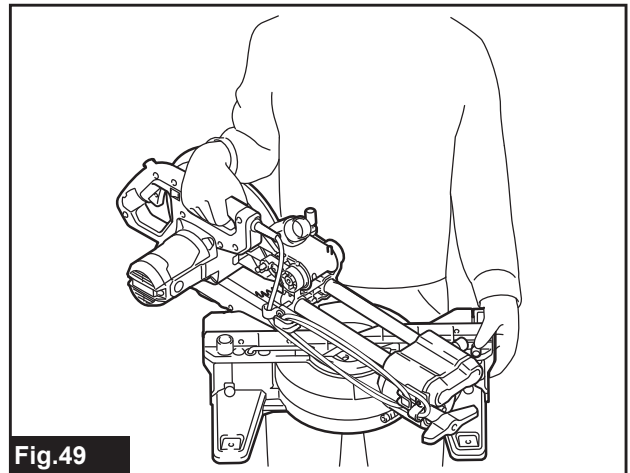

Fig.49

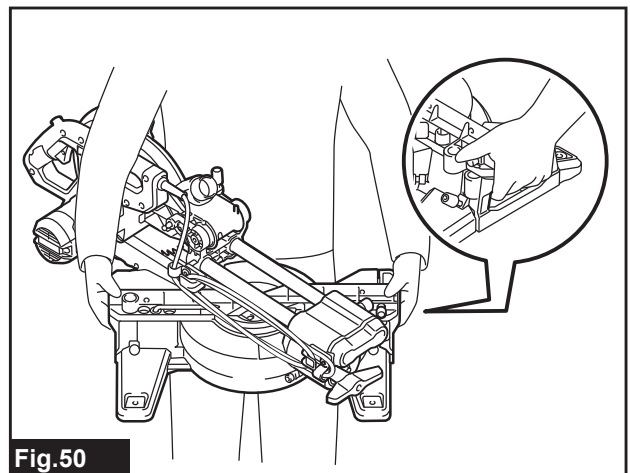

Fig.50

⚠ WARNING: Stopper pin for carriage elevation is for carrying, storage, and adjustment purposes only and not for any cutting operations. The use of the stopper pin for cutting operations may cause unexpected movement of the circular saw blade resulting in kickback and serious personal injury.

⚠CAUTION: Always secure all moving portions before carrying the tool. If portions of the tool move or slide while being carried, loss of control or balance may occur and result in personal injury.

⚠CAUTION: Be sure that the carriage elevation is properly locked at its bottom by the stopper pin. If the stopper pin is not engaged properly, the carriage may jump up suddenly and cause personal injury.

MAINTENANCE

⚠WARNING: Always be sure that the tool is switched off and unplugged before attempting to perform inspection or maintenance. Failure to unplug and switch off the tool may result in accidental startup of the tool which may result in serious personal injury.

⚠WARNING: Always be sure that the saw blade is sharp and clean for the best and safest performance. Attempting a cut with a dull and /or dirty saw blade may cause kickback and result in a serious personal injury.

NOTICE: Never use gasoline, benzene, thinner, alcohol or the like. Discoloration, deformation or cracks may result.

To maintain product SAFETY and RELIABILITY, repairs, any other maintenance or adjustment should be performed by Makita Authorized or Factory Service Centers, always using Makita replacement parts.

Adjusting the cutting angle

This tool is carefully adjusted and aligned at the factory, but rough handling may have affected the alignment. If your tool is not aligned properly, perform the following:

Miter angle

1. Lock the carriage in the lowered position by the stopper pin. Push the carriage toward the guide fence and tighten the thumb screw to secure the carriage.
2. Set the turn base to the 0° position using the positive stop function. (Leave as it is if the pointer does not point to 0°.)
3. Loosen the hex socket bolts securing the guide fence using the hex wrench.

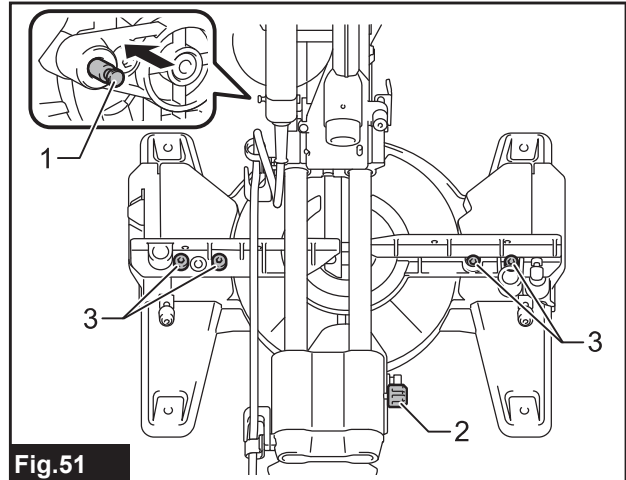

Fig.51

- 1. Stopper pin 2. Thumb screw 3. Hex socket bolts

4. Square the side of the saw blade with the face of the guide fence using a triangular rule or try-square. Then securely tighten the hex socket bolts on the guide fence in order from the right side.

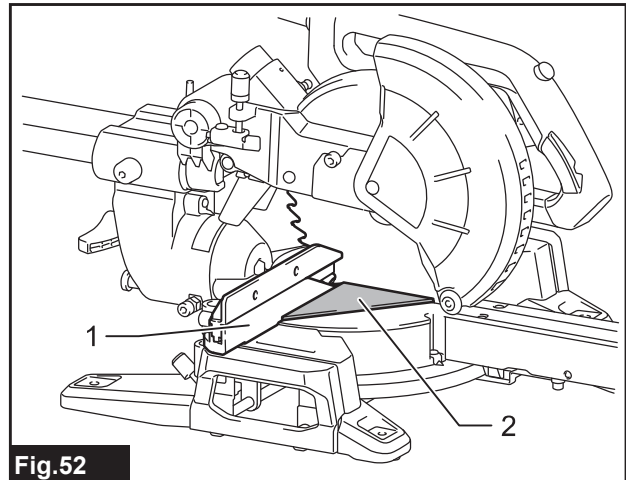

Fig.52

- 1. Guide fence 2. Triangular rule

- If the pointer does not point to 0°, loosen the screw which secures the pointer and adjust the pointer so that it points 0°.

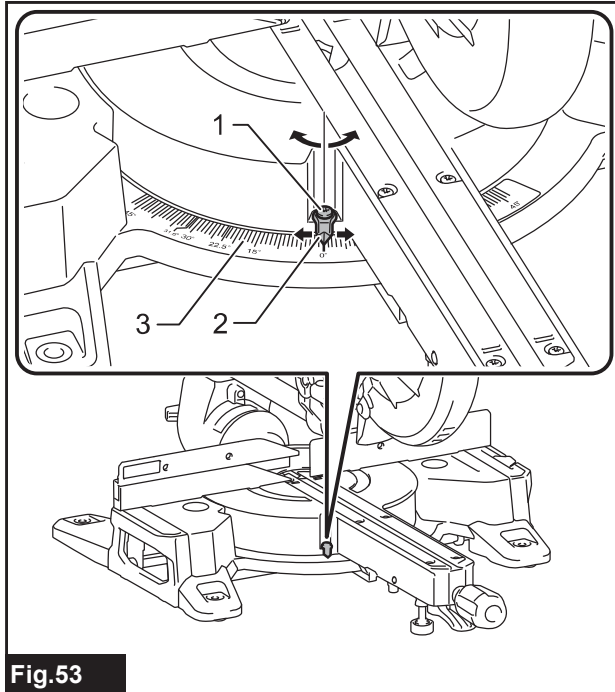

Fig.53

- 1. Screw 2. Pointer 3. Miter scale

Bevel angle

0° bevel angle

- Lock the carriage in the lowered position by the stopper pin. Push the carriage toward the guide fence and tighten the thumb screw to secure the carriage.
- Loosen the lever. Then turn the 0° adjusting bolt two or three revolutions counterclockwise to tilt the circular saw blade to the right.

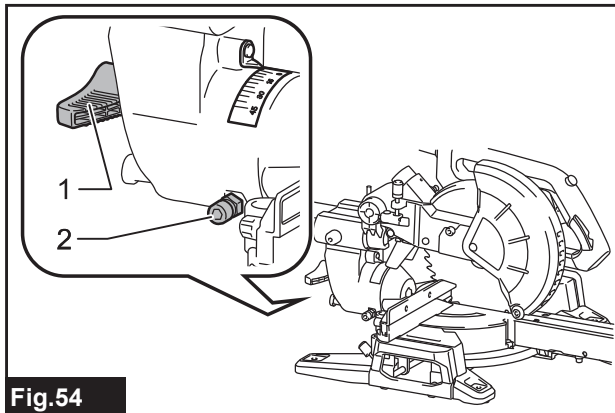

Fig.54

- 1. Lever 2. 0° Adjusting bolt

- Carefully square the side of the saw blade with the top surface of the turn base using the triangular rule, try-square, etc. by turning the 0° adjusting bolt clockwise. Then tighten the lever firmly to secure the 0° angle you have set.

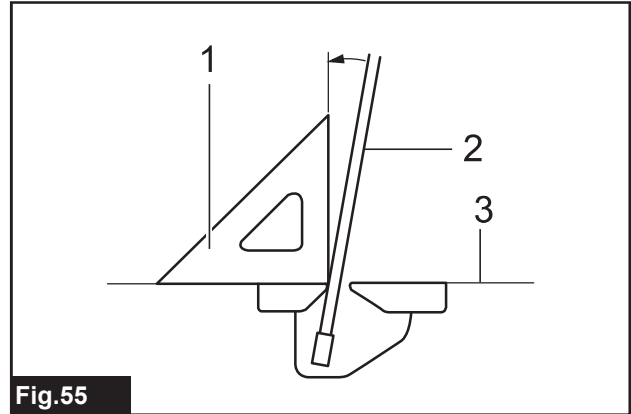

Fig.55

- 1. Triangular rule 2. Saw blade 3. Top surface of turn base

- If the pointer does not point 0°, loosen the screw which secure the pointer and adjust it so that it points 0°.

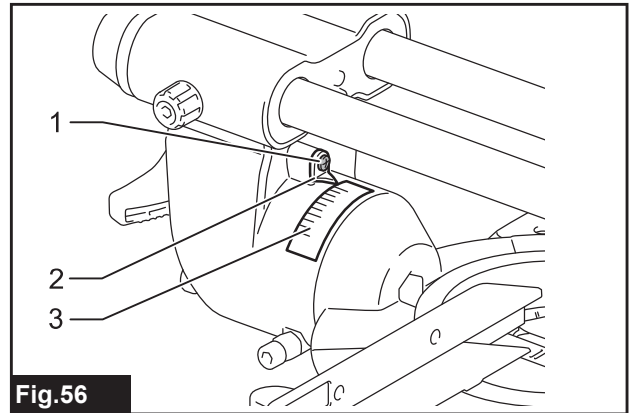

Fig.56

- 1. Screw 2. Pointer 3. Bevel scale

45° bevel angle

NOTICE: Before adjusting the 45° bevel angle, finish 0° bevel angle adjustment.

- Tighten the thumb screw to secure the carriage.
- Loosen the lever. Then fully tilt the carriage to the left.

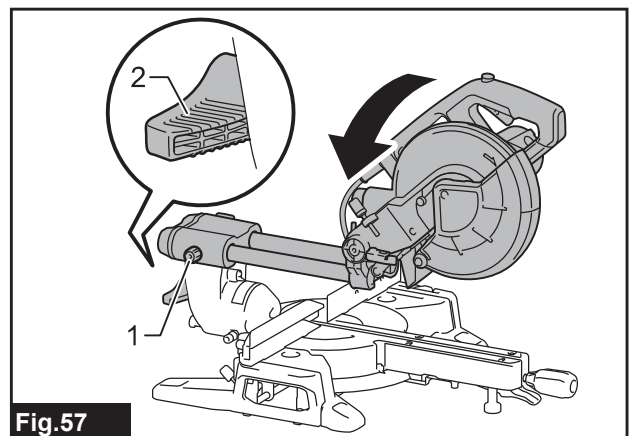

Fig.57

- 1. Thumb screw 2. Lever

3. Check if the pointer indicates the 45° position in the bevel angle scale.

If the pointer does not indicate the 45° position, align it with 45° position by turning the 45° adjusting bolt.

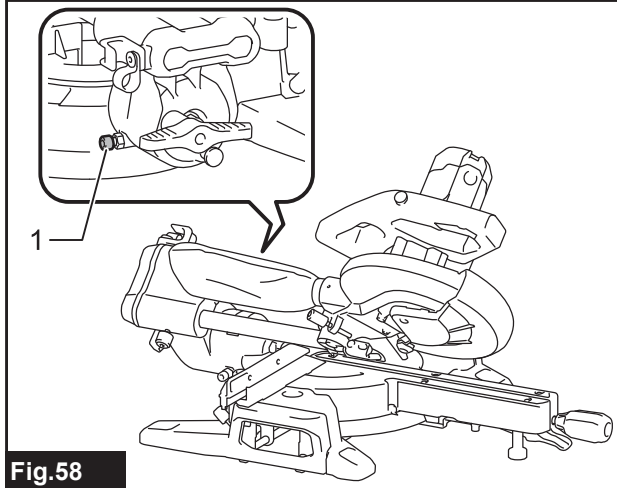

Fig.58

► 1. 45° adjusting bolt

Replacing carbon brushes

Remove and check the carbon brushes regularly. Replace when they wear down to 3 mm (1/8") in length. Keep the carbon brushes clean and free to slip in the holders. Both carbon brushes should be replaced at the same time. Use only identical carbon brushes.

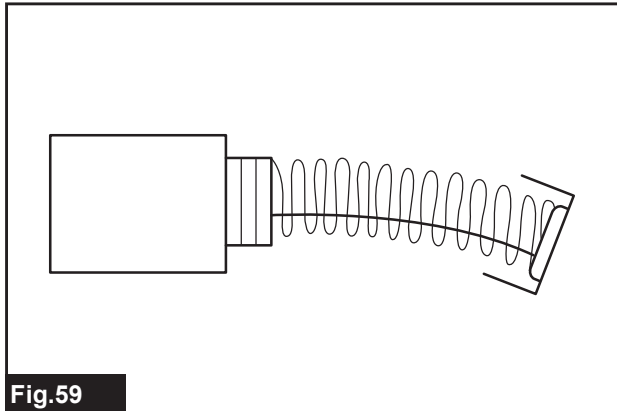

Fig.59

Use a screwdriver to remove the brush holder caps. Take out the worn carbon brushes, insert the new ones and secure the brush holder caps.

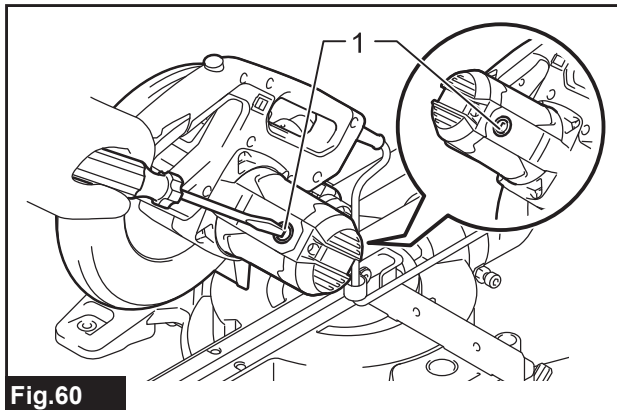

Fig.60

► 1. Brush holder cap

After replacing brushes, plug in the tool and break in brushes by running tool with no load for about 10 minutes. Then check the tool while running and electric brake operation when releasing the switch trigger. If the electric brake is not working correctly, have the tool repaired by a Makita service center.

After use

After use, wipe off chips and dust adhering to the tool with a cloth or the like. Keep the blade guard clean according to the directions in the previously covered section titled "Blade guard". Lubricate the sliding portions with machine oil to prevent rust.

OPTIONAL ACCESSORIES

⚠ WARNING: These Makita accessories or attachments are recommended for use with your Makita tool specified in this manual. The use of any other accessories or attachments may result in serious personal injury.

⚠ WARNING: Only use the Makita accessory or attachment for its stated purpose. Misuse of an accessory or attachment may result in serious personal injury.

If you need any assistance for more details regarding these accessories, ask your local Makita Service Center.

- Steel & Carbide-tipped saw blade
- Vertical vise
- Dust bag
- Triangular rule
- Hex wrench
- Stand set

NOTE: Some items in the list may be included in the tool package as standard accessories. They may differ from country to country.

אחזקה

בכל מקרה של תקלה יש להביא את המכשיר לחנות שממנה נקנה ו/או למעבדה מורשית ע"י חברת ארגנטולס לביצוע תיקונים בכלי עבודה מקיטה.

Makita Corporation
3-11-8, Sumiyoshi-cho,
Anjo, Aichi 446-8502 Japan
www.makita.com

LS1110F-
ENAU-HE-2306
EN, HE
20230808