

INSTRUCTION MANUAL

# Multi Tool

## M9800

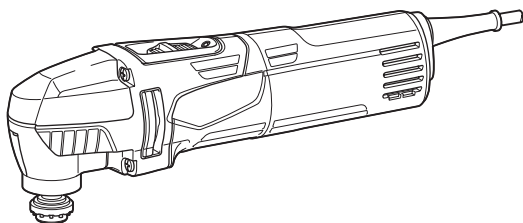

DOUBLE INSULATION



Read before use.





# SPECIFICATIONS

<b>Model:</b>	<b>M9800</b>
Oscillation per minute	15,000 - 22,000 min <sup>-1</sup>
Oscillation angle, left/right	1.6 ° (3.2 ° total)
Overall length	283 mm
Net weight	1.2 - 1.3 kg
Safety class	□/II

- Due to our continuing program of research and development, the specifications herein are subject to change without notice.
- Specifications may differ from country to country.
- The weight may differ depending on the attachment(s). The lightest and heaviest combination, according to EPTA-Procedure 01/2014, are shown in the table.

## Symbols

The followings show the symbols used for the equipment. Be sure that you understand their meaning before use.

	Read instruction manual.
	Wear safety glasses.
	DOUBLE INSULATION
	Only for EU countries Do not dispose of electric equipment together with household waste material! In observance of the European Directive, on Waste Electric and Electronic Equipment and its implementation in accordance with national law, electric equipment that have reached the end of their life must be collected separately and returned to an environmentally compatible recycling facility.

## Intended use

The tool is intended for sawing and cutting wood, plastic, gypsum, non-ferrous metals, and fastening elements (e. g. unhardened nails and staples). It is also intended for working soft wall tiles, as well as dry sanding and scraping of small surfaces. It is especially for working close to edge and flush cutting.

## Power supply

The tool should be connected only to a power supply of the same voltage as indicated on the nameplate, and can only be operated on single-phase AC supply. They are double-insulated and can, therefore, also be used from sockets without earth wire.

## Noise

Work mode	Sound pressure level (L <sub>pa</sub> ) :	Uncertainty (K)	Applicable standard
Sanding	78 dB(A)	3 dB(A)	EN62841-2-4
Cutting with plunge cut saw blade	79 dB(A)	3 dB(A)	EN62841-1
Cutting with segmental saw blade	79 dB(A)	3 dB(A)	EN62841-1
Scraping	78 dB(A)	3 dB(A)	EN62841-1

The noise level under working may exceed 80 dB (A).

**NOTE:** The declared noise emission value(s) has been measured in accordance with a standard test method and may be used for comparing one tool with another.

**NOTE:** The declared noise emission value(s) may also be used in a preliminary assessment of exposure.

**⚠ WARNING:** Wear ear protection.

**⚠ WARNING:** The noise emission during actual use of the power tool can differ from the declared value(s) depending on the ways in which the tool is used especially what kind of workpiece is processed.

**⚠ WARNING:** Be sure to identify safety measures to protect the operator that are based on an estimation of exposure in the actual conditions of use (taking account of all parts of the operating cycle such as the times when the tool is switched off and when it is running idle in addition to the trigger time).

## Vibration

The following table shows the vibration total value (tri-axial vector sum) determined according to applicable standard.

Work mode	Vibration emission	Uncertainty (K)	Applicable standard
Sanding ( $a_h$ )	2.5 m/s <sup>2</sup>	1.5 m/s <sup>2</sup>	EN62841-2-4
Cutting with plunge cut saw blade ( $a_h$ )	8.0 m/s <sup>2</sup>	1.5 m/s <sup>2</sup>	EN62841-1-1
Cutting with segmental saw blade ( $a_h$ )	4.0 m/s <sup>2</sup>	1.5 m/s <sup>2</sup>	EN62841-1-1
Scraping ( $a_h$ )	9.5 m/s <sup>2</sup>	1.5 m/s <sup>2</sup>	EN62841-1-1

**NOTE:** The declared vibration total value(s) has been measured in accordance with a standard test method and may be used for comparing one tool with another.

**NOTE:** The declared vibration total value(s) may also be used in a preliminary assessment of exposure.

**⚠ WARNING:** The vibration emission during actual use of the power tool can differ from the declared value(s) depending on the ways in which the tool is used especially what kind of workpiece is processed.

**⚠ WARNING:** Be sure to identify safety measures to protect the operator that are based on an estimation of exposure in the actual conditions of use (taking account of all parts of the operating cycle such as the times when the tool is switched off and when it is running idle in addition to the trigger time).

## EC Declaration of Conformity

### For European countries only

The EC declaration of conformity is included as Annex A to this instruction manual.

## SAFETY WARNINGS

### General power tool safety warnings

**⚠ WARNING:** Read all safety warnings, instructions, illustrations and specifications provided with this power tool. Failure to follow all instructions listed below may result in electric shock, fire and/or serious injury.

### Save all warnings and instructions for future reference.

The term "power tool" in the warnings refers to your mains-operated (corded) power tool or battery-operated (cordless) power tool.

#### Work area safety

1. **Keep work area clean and well lit.** Cluttered or dark areas invite accidents.
2. **Do not operate power tools in explosive atmospheres, such as in the presence of flammable liquids, gases or dust.** Power tools create sparks which may ignite the dust or fumes.
3. **Keep children and bystanders away while operating a power tool.** Distractions can cause you to lose control.

#### Electrical Safety

1. **Power tool plugs must match the outlet. Never modify the plug in any way. Do not use any adapter plugs with earthed (grounded) power tools.** Unmodified plugs and matching outlets will reduce risk of electric shock.
2. **Avoid body contact with earthed or grounded surfaces, such as pipes, radiators, ranges and refrigerators.** There is an increased risk of electric shock if your body is earthed or grounded.

3. **Do not expose power tools to rain or wet conditions.** Water entering a power tool will increase the risk of electric shock.
4. **Do not abuse the cord. Never use the cord for carrying, pulling or unplugging the power tool. Keep cord away from heat, oil, sharp edges or moving parts.** Damaged or entangled cords increase the risk of electric shock.
5. **When operating a power tool outdoors, use an extension cord suitable for outdoor use.** Use of a cord suitable for outdoor use reduces the risk of electric shock.
6. **If operating a power tool in a damp location is unavoidable, use a residual current device (RCD) protected supply.** Use of an RCD reduces the risk of electric shock.
7. **Use of power supply via an RCD with a rated residual current of 30 mA or less is always recommended.**
8. **Power tools can produce electromagnetic fields (EMF) that are not harmful to the user.** However, users of pacemakers and other similar medical devices should contact the maker of their device and/or doctor for advice before operating this power tool.
9. **Do not touch the power plug with wet hands.**
10. **If the cord is damaged, have it replaced by the manufacturer or his agent in order to avoid a safety hazard.**

#### Personal Safety

1. **Stay alert, watch what you are doing and use common sense when operating a power tool. Do not use a power tool while you are tired or under the influence of drugs, alcohol or medication.** A moment of inattention while operating power tools may result in serious personal injury.
2. **Use personal protective equipment. Always wear eye protection.** Protective equipment such as a dust mask, non-skid safety shoes, hard hat or hearing protection used for appropriate conditions will reduce personal injuries.
3. **Prevent unintentional starting. Ensure the switch is in the off-position before connecting to power source and/or battery pack, picking up or carrying the tool.** Carrying power tools with your finger on the switch or energising power tools that have the switch on invites accidents.

4. **Remove any adjusting key or wrench before turning the power tool on.** A wrench or a key left attached to a rotating part of the power tool may result in personal injury.
5. **Do not overreach. Keep proper footing and balance at all times.** This enables better control of the power tool in unexpected situations.
6. **Dress properly. Do not wear loose clothing or jewellery. Keep your hair and clothing away from moving parts.** Loose clothes, jewellery or long hair can be caught in moving parts.
7. **If devices are provided for the connection of dust extraction and collection facilities, ensure these are connected and properly used.** Use of dust collection can reduce dust-related hazards.
8. **Do not let familiarity gained from frequent use of tools allow you to become complacent and ignore tool safety principles.** A careless action can cause severe injury within a fraction of a second.
9. **Always wear protective goggles to protect your eyes from injury when using power tools. The goggles must comply with ANSI Z87.1 in the USA, EN 166 in Europe, or AS/NZS 1336 in Australia/New Zealand. In Australia/New Zealand, it is legally required to wear a face shield to protect your face, too.**

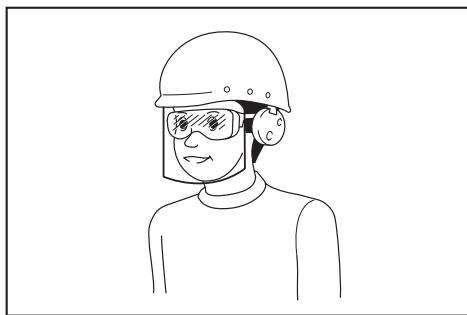

It is an employer's responsibility to enforce the use of appropriate safety protective equipments by the tool operators and by other persons in the immediate working area.

#### Power tool use and care

1. **Do not force the power tool. Use the correct power tool for your application.** The correct power tool will do the job better and safer at the rate for which it was designed.
  2. **Do not use the power tool if the switch does not turn it on and off.** Any power tool that cannot be controlled with the switch is dangerous and must be repaired.
  3. **Disconnect the plug from the power source and/or remove the battery pack, if detachable, from the power tool before making any adjustments, changing accessories, or storing power tools.** Such preventive safety measures reduce the risk of starting the power tool accidentally.
  4. **Store idle power tools out of the reach of children and do not allow persons unfamiliar with the power tool or these instructions to operate the power tool.** Power tools are dangerous in the hands of untrained users.
5. **Maintain power tools and accessories. Check for misalignment or binding of moving parts, breakage of parts and any other condition that may affect the power tool's operation. If damaged, have the power tool repaired before use.** Many accidents are caused by poorly maintained power tools.
  6. **Keep cutting tools sharp and clean.** Properly maintained cutting tools with sharp cutting edges are less likely to bind and are easier to control.
  7. **Use the power tool, accessories and tool bits etc. in accordance with these instructions, taking into account the working conditions and the work to be performed.** Use of the power tool for operations different from those intended could result in a hazardous situation.
  8. **Keep handles and grasping surfaces dry, clean and free from oil and grease.** Slippery handles and grasping surfaces do not allow for safe handling and control of the tool in unexpected situations.
  9. **When using the tool, do not wear cloth work gloves which may be entangled.** The entanglement of cloth work gloves in the moving parts may result in personal injury.

#### Service

1. **Have your power tool serviced by a qualified repair person using only identical replacement parts.** This will ensure that the safety of the power tool is maintained.
2. **Follow instruction for lubricating and changing accessories.**

### Multi tool safety warnings

1. **This power tool is intended to function for sawing, cutting, grinding and sanding. Read all safety warnings, instructions, illustrations and specifications provided with this power tool.** Failure to follow all instructions listed below may result in electric shock, fire and/or serious injury.
2. **Hold the power tool by insulated gripping surfaces, when performing an operation where the cutting accessory may contact hidden wiring or its own cord.** Cutting accessory contacting a "live" wire may make exposed metal parts of the power tool "live" and could give the operator an electric shock.
3. **Use clamps or another practical way to secure and support the workpiece to a stable platform.** Holding the work by hand or against your body leaves it unstable and may lead to loss of control.
4. **Position the cord clear of the spinning accessory.** If you lose control, the cord may be cut or snagged and your hand or arm may be pulled into the spinning accessory.
5. **Always use safety glasses or goggles.** Ordinary eye or sun glasses are NOT safety glasses.
6. **Avoid cutting nails. Inspect workpiece for any nails and remove them before operation.**
7. **Hold the tool firmly.**
8. **Make sure the application tool is not contacting the workpiece before the switch is turned on.**
9. **Keep hands away from moving parts.**
10. **Do not leave the tool running. Operate the tool only when hand-held.**

11. Always switch off and wait for the blade to come to a complete stop before removing the blade from the workpiece.
12. Do not touch the application tool or the workpiece immediately after operation; they may be extremely hot and could burn your skin.
13. Do not operate the tool at no-load unnecessarily.
14. Always use the correct dust mask/respirator for the material and application you are working with.
15. Some material contains chemicals which may be toxic. Take caution to prevent dust inhalation and skin contact. Follow material supplier safety data.
16. This tool has not been waterproofed, so do not use water on the workpiece surface.
17. Ventilate your work area adequately when you perform sanding operations.
18. Use of this tool to sand some products, e.g. leaded paint surfaces, wood and metals could expose user and bystanders to dust containing hazardous substances. Use appropriate respiratory protection.
19. Be sure that there are no cracks or breakage on the pad before use. Cracks or breakage may cause a personal injury.
20. Do not use accessories which are not specifically designed and recommended by the tool manufacturer. Just because the accessory can be attached to your power tool, it does not assure safe operation.
21. Wear personal protective equipment. Depending on application, use face shield, safety goggles or safety glasses. As appropriate, wear hearing protectors, gloves and workshop apron capable of stopping small abrasive or workpiece fragments. The eye protection must be capable of stopping flying debris generated by various operations. The dust mask or respirator must be capable of filtering particles generated by your operation. Prolonged exposure to high intensity noise may cause hearing loss.
22. Keep bystanders a safe distance away from work area. Anyone entering the work area must wear personal protective equipment. Fragments of workpiece or of a broken accessory may fly away and cause injury beyond immediate area of operation.
23. Never lay the power tool down until the accessory has come to a complete stop. The spinning accessory may grab the surface and pull the power tool out of your control.
24. Do not run the power tool while carrying it at your side. Accidental contact with the accessory could snag your clothing, pulling the accessory into your body.
25. Do not operate the power tool near flammable materials. Sparks could ignite these materials.
26. Do not use accessories that require liquid coolants. Using water or other liquid coolants may result in electrocution or shock.
27. Always be sure that the tool is switched off and unplugged before carrying out any work on the tool.
28. If working place is extremely hot and humid, or badly polluted by conductive dust, use a short-circuit breaker (30 mA) to assure operator safety.
29. Always be sure you have a firm footing. Be sure no one is below when using the tool in high locations.
30. Before starting operation, make sure that there is no hidden supply lines such as electric, gas and water lines under the working surface. Cutting or damaging the supply lines may cause electric shock, gas leakage, property damage, or other accidents.

## SAVE THESE INSTRUCTIONS.

**⚠WARNING:** DO NOT let comfort or familiarity with product (gained from repeated use) replace strict adherence to safety rules for the subject product. MISUSE or failure to follow the safety rules stated in this instruction manual may cause serious personal injury.

## FUNCTIONAL DESCRIPTION

**⚠CAUTION:** Always be sure that the tool is switched off and unplugged before adjusting or checking function on the tool.

## Switch action

**⚠CAUTION:** Before plugging in the tool, always check to see that the tool is switched off.

To start the tool, slide the slide switch toward the "I (ON)" position.  
To stop the tool, slide the slide switch toward the "O (OFF)" position.

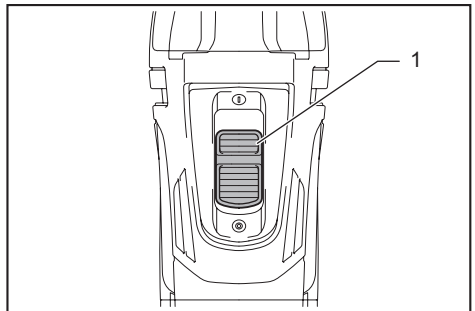

► 1. Slide switch

## Adjusting the orbital stroke rate

The orbital stroke rate is adjustable. To change the orbital stroke rate, turn the dial between 1 and 5. The higher the number is, the higher the orbital stroke rate is. Preset the dial to the number suitable for your workpiece.

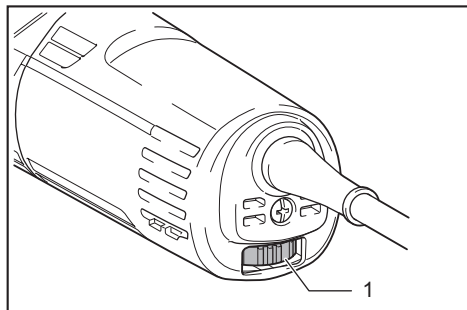

► 1. Dial

**NOTE:** The dial cannot be turned directly from 1 to 5 or from 5 to 1. Forcing the dial may damage the tool. When changing the dial direction, always turn the dial moving it through each intermediate number.

## ASSEMBLY

**CAUTION:** Always be sure that the tool is switched off and unplugged before carrying out any work on the tool.

### Installing or removing application tool

#### Optional accessory

**WARNING:** Do not install application tool upside down. Installing application tool upside down may damage the tool and cause serious personal injury.

**WARNING:** Install attachment tool in the correct direction according to your work. Application tool can be installed at an angle of every 30 degree.

**WARNING:** Always install the application tool so that the protrusions of the tool flange fit in the holes on the application tool. Failure to do so may cause the application tool flown off and result in personal injury.

**WARNING:** When installing the application tool, be sure to tighten the application tool installation bolt securely.

Put an application tool (optional accessory) on the tool flange so that the protrusions of the tool flange fit in the holes in the application tool and secure the application tool by tightening the bolt firmly with the hex wrench. When using sanding application tool, mount the application tool on the sanding pad so that it matches the sanding pad direction. The sanding pad has a hook and loop type fitting system which allows easy and rapid fitting of a sanding paper.

As sanding papers have holes for dust extraction, mount a sanding paper so that the holes in a sanding paper match those in the sanding pad.

To remove a sanding paper, raise its end and peel it off. Loosen and remove the application tool installation bolt using a hex wrench and then take off the application tool.

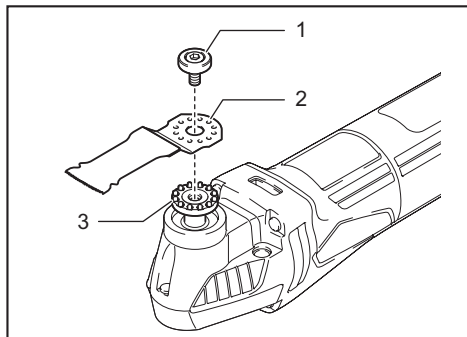

► 1. Application tool installation bolt 2. Holes in the application tool 3. Protrusions of the tool flange

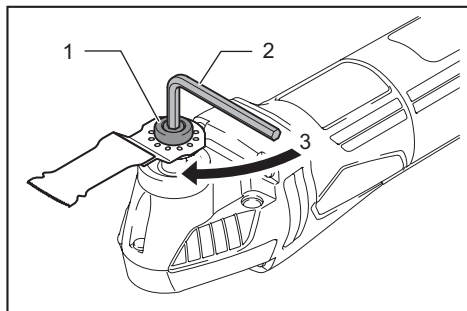

► 1. Application tool installation bolt 2. Hex wrench 3. Tighten

When using application tools with a different type of installation section, use a correct adapter (optional accessory).

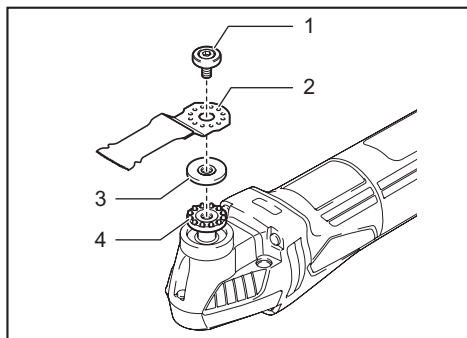

► 1. Application tool installation bolt 2. Holes in the application tool 3. Adapter 4. Protrusions of the tool flange

## OPERATION

**⚠WARNING:** Before starting the tool and during operation, keep your hand and face away from the application tool.

**⚠CAUTION:** Do not apply excessive load to the tool which may cause a motor lock and stop the tool.

### Cutting, sawing and scraping

**⚠CAUTION:** Do not move on the tool forcibly in the direction (eg. towards either side) of tool application with no cutting edge. It may damage the tool.

Put the application tool on the workpiece. And then move the tool forward so that the application tool movement does not slow down.

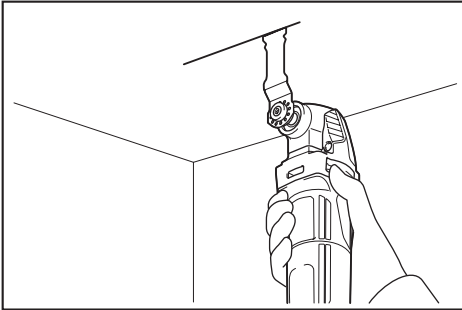

**NOTE:** Forcing or excessive pressure on the tool may reduce efficiency.

**NOTE:** Before cutting operation, it is recommended to preset the orbital stroke rate 3 - 5.

### Sanding

**⚠CAUTION:** Do not reuse a sanding paper used for sanding metal to sand wood.

**⚠CAUTION:** Do not use a worn sanding paper or sanding paper without grit.

Apply a sanding paper on the workpiece.

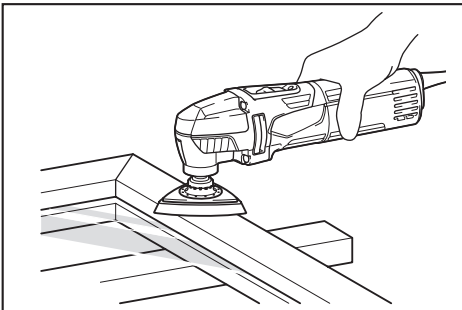

**NOTE:** Using a test material sample to try is recommendable to determine a correct orbital stroke rate suitable for your work.

**NOTE:** Use a sanding paper with the same grit until sanding the whole workpiece is completed. Replacing a sanding paper with different grit sanding paper may not get a fine finish.

### Dust extraction attachment

#### Optional accessory

**⚠WARNING:** Do not use extraction attachment when grinding a metallic workpiece with this tool. Hot dust may ignite dust in the vacuum cleaner and it may cause fire.

When you wish to perform cleaner operation, install the dust extraction attachment to the tool. Connect a hose of vacuum cleaner to the dust extraction attachment.

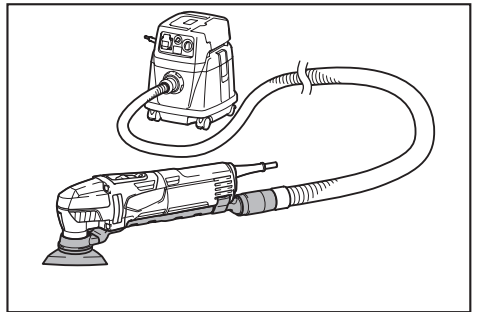

Assemble the dust extraction attachment and install it to the tool.

1. Install joint, dust nozzle and dust attachment.
2. Install the nozzle band on the tool so that its protrusions fit in the holes in the tool to secure it.

3. Put the felt ring, spacer (if necessary), and the sanding pad on the dust attachment and then secure them with the application tool installation bolt.

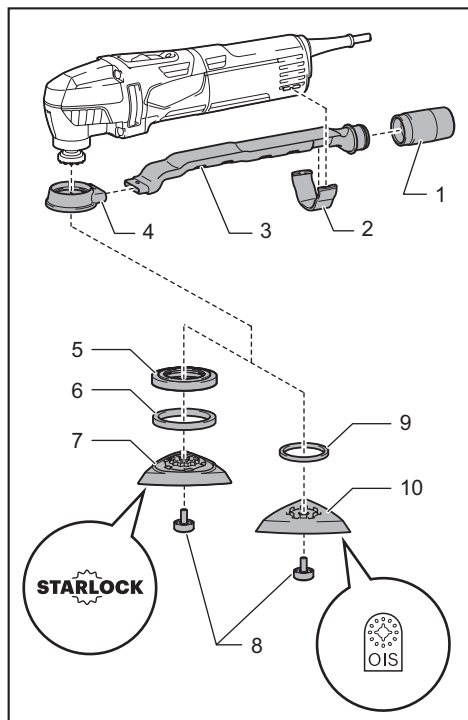

- 1. Joint 2. Nozzle band 3. Dust nozzle 4. Dust attachment 5. Spacer 6. Felt ring (ø 47 mm) 7. Pad (with STARLOCK marking) 8. Application tool installation bolt 9. Felt ring (ø 37 mm) 10. Pad (with OIS marking)

**NOTICE:** When using the pad with STARLOCK marking, be sure to install the spacer between the dust attachment and the felt ring.

## MAINTENANCE

**CAUTION:** Always be sure that the tool is switched off and unplugged before attempting to perform inspection or maintenance.

**NOTICE:** Never use gasoline, benzine, thinner, alcohol or the like. Discoloration, deformation or cracks may result.

To maintain product SAFETY and RELIABILITY, repairs, any other maintenance or adjustment should be performed by Makita Authorized or Factory Service Centers, always using Makita replacement parts.

## Cleaning

From time to time wipe off the tool using a dry cloth or a cloth dampened in soapy water.

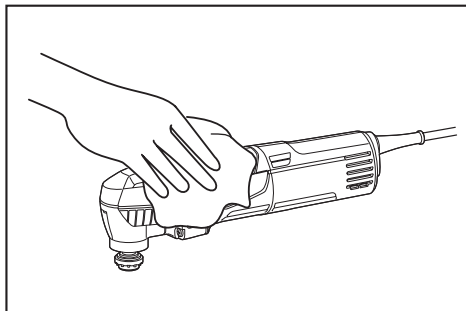









**Makita Europe N.V.** Jan-Baptist Vinkstraat 2,  
3070 Kortenberg, Belgium

**Makita Corporation** 3-11-8, Sumiyoshi-cho,  
Anjo, Aichi 446-8502 Japan

[www.makita.com](http://www.makita.com)

885697-220 EN 20181130
------------------------------