

INSTRUCTION MANUAL

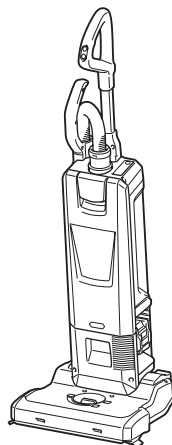

Cordless Upright Cleaner

VC010G



  Read before use.

WARNING

- For users in Europe: This appliance can be used by children aged from 8 years and above and persons with reduced physical, sensory or mental capabilities or lack of experience and knowledge if they have been given supervision or instruction concerning use of the appliance in a safe way and understand the hazards involved. Children shall not play with the appliance. Cleaning and user maintenance shall not be made by children without supervision.
- For users in areas other than Europe: This appliance is not intended for use by persons (including children) with reduced physical, sensory or mental capabilities, or lack of experience and knowledge, unless they have been given supervision or instruction concerning use of the appliance by a person responsible for your safety.
- Children must be supervised to ensure that they do not play with the appliance.
- CAUTION: Before carrying out any maintenance operation, disconnect the appliance from the power supply. Perform maintenance on the appliance periodically.
- Rechargeable batteries must be removed from the device before charging.
- To remove or install the battery, slide the cartridge out of the tool while pressing the button on the front of the cartridge.
- Exhausted batteries must be removed from the device and disposed of safely. Follow local regulations regarding battery disposal.
- If the device is to be stored unused for a long period, the batteries should be removed.
- The power terminals must not be short-circuited.

Applicable battery cartridge and charger

Battery cartridge	BL4020 / BL4025 / BL4040 / BL4040F / BL4050F / BL4080F
Charger	DC40RA / DC40RB / DC40RC

- Some of the battery cartridges and chargers listed above may not be available depending on your region of residence.

⚠ WARNING: Only use the battery cartridges and chargers listed above. Use of any other battery cartridges and chargers may cause injury and/or fire.

SPECIFICATIONS

Model:	VC010G
Maximum air volume ^{*1}	1.8 m ³ /min
Vacuum ^{*1}	15 kPa
Capacity	5 L
Dimensions (L x W x H)	326 mm x 381 mm x 1,146 mm
Rated voltage	D.C. 36 V - 40 V max
Net weight	8.0 - 9.2 kg

^{*1} The value is measured by our original method.

- Due to our continuing program of research and development, the specifications herein are subject to change without notice.
- Specifications may differ from country to country.
- The weight includes accessories (round brush, corner nozzle) and battery cartridge(s). The lightest and heaviest combination weight of the appliance and battery cartridge(s) are shown in the table.

Symbols

The followings show the symbols which may be used for the equipment. Be sure that you understand their meaning before use.



Read instruction manual.



Take particular care and attention.



A representative battery applicable to this product.



Only for EU countries
Due to the presence of hazardous components in the equipment, waste electrical and electronic equipment, accumulators and batteries may have a negative impact on the environment and human health. Do not dispose of electrical and electronic appliances or batteries with household waste!
In accordance with the European Directive on waste electrical and electronic equipment and on accumulators and batteries and waste accumulators and batteries, as well as their adaptation to national law, waste electrical equipment, batteries and accumulators should be stored separately and delivered to a separate collection point for municipal waste, operating in accordance with the regulations on environmental protection.
This is indicated by the symbol of the crossed-out wheeled bin placed on the equipment.

Intended use

The appliance is intended for collecting dry dust. The appliance is suitable for commercial use, for example in hotels, schools, hospitals, factories, shops, offices and rental businesses.

Noise

The typical A-weighted noise level determined according to IEC60335-2-69:

Sound pressure level (L_{pA}) : 70 dB(A) or less

Uncertainty (K) : 2.5 dB (A)

The noise level under working may exceed 80 dB (A).

NOTE: The declared noise emission value(s) has been measured in accordance with a standard test method and may be used for comparing one tool with another.

NOTE: The declared noise emission value(s) may also be used in a preliminary assessment of exposure.

⚠WARNING: Wear ear protection.

⚠WARNING: The noise emission during actual use of the power tool can differ from the declared value(s) depending on the ways in which the tool is used especially what kind of workpiece is processed.

⚠WARNING: Be sure to identify safety measures to protect the operator that are based on an estimation of exposure in the actual conditions of use (taking account of all parts of the operating cycle such as the times when the tool is switched off and when it is running idle in addition to the trigger time).

Vibration

The vibration total value (tri-axial vector sum) determined according to IEC60335-2-69:

Vibration emission ($a_{h,M}$) : 2.5 m/s^2 or less

Uncertainty (K) : 1.5 m/s^2

NOTE: The declared vibration total value(s) has been measured in accordance with a standard test method and may be used for comparing one tool with another.

NOTE: The declared vibration total value(s) may also be used in a preliminary assessment of exposure.

⚠WARNING: The vibration emission during actual use of the power tool can differ from the declared value(s) depending on the ways in which the tool is used especially what kind of workpiece is processed.

⚠WARNING: Be sure to identify safety measures to protect the operator that are based on an estimation of exposure in the actual conditions of use (taking account of all parts of the operating cycle such as the times when the tool is switched off and when it is running idle in addition to the trigger time).

Declarations of Conformity

For European countries only

The Declarations of conformity are included in Annex A to this instruction manual.

SAFETY WARNINGS

Cordless vacuum cleaner safety warnings

⚠WARNING: IMPORTANT! READ CAREFULLY all safety warnings and all instructions **BEFORE USE**. Failure to follow the warnings and instructions may result in electric shock, fire and/or serious injury.

1. **Before use, make sure that this cleaner must be used by people who have been adequately instructed on the use of this cleaner.**
2. **Do not use without filter bag and/or filters in place. Replace a damaged filter immediately.**

3. **AVOID UNINTENTIONAL STARTING.** Be sure switch is OFF when installing battery(ies).
4. Do not attempt to pick up flammable materials, fireworks, lighted cigarettes, hot ashes, hot metal chips, sharp materials such as razors, needles, broken glass or the like.
5. **NEVER USE THE CLEANER IN THE VICINITY OF GASOLINE, GAS, PAINT, ADHESIVES OR OTHER HIGHLY EXPLOSIVE SUBSTANCES.** The switch emits sparks when turned ON and OFF. And so does the motor commutator during operation. A dangerous explosion may result.
6. This cleaner is not suitable for picking up hazardous dust.
7. Never vacuum up toxic, carcinogenic, combustible or other hazardous materials such as asbestos, arsenic, barium, beryllium, lead, pesticides, or other health endangering materials.
8. Do not vacuum foam like carpet cleaning agent, etc. It may cause explosion or fire.
9. Do not use outdoors or on wet surfaces.
10. For Finland, this machine is not to be used outdoors at low temperature.
11. Do not use the appliance close to heat sources (stoves, etc.).
12. Do not block suction inlet/outlet/cooling vents. These vents permit cooling of the motor. Blockage should be carefully avoided otherwise the motor will burn out due to a lack of ventilation.
13. Do not fold, tug or step on the hose.
14. Stop the cleaner immediately if you notice poor performance or anything abnormal during operation.
15. **REMOVE THE BATTERY(IES).** When not in use, before servicing, and when changing accessories.
16. Clean and service the cleaner immediately after each use to keep it in optimum operating condition.
17. **MAINTAIN THE CLEANER WITH CARE.** Keep the cleaner clean for better and safer performance. Follow instructions for changing accessories. Keep handles dry, clean, and free from oil and grease.
18. **CHECK DAMAGED PARTS.** Before further use of the cleaner, a guard or other part that is damaged should be carefully checked to determine that it will operate properly and perform its intended function. Check for alignment of moving parts, binding of moving parts, breakage of parts, mounting, and any other conditions that may affect its operation. A guard or other part that is damaged should be properly repaired or replaced by an authorized service center unless otherwise indicated elsewhere in this instruction manual. Have defective switches replaced by authorized service center. Don't use the cleaner if switch does not turn it on and off.
19. **REPLACEMENT PARTS.** When servicing, use only identical replacement parts.
20. When not in use, always store the cleaner indoors.
21. **Be kind to your cleaner.** Rough handling can cause breakage of even the most sturdily built cleaner.
22. Do not attempt to clean the exterior or interior with benzene, thinner or cleaning chemicals. Cracks and discoloration may be caused.
23. Do not use cleaner in an enclosed space where flammable, explosive or toxic vapors are given off by oil-based paint, paint-thinner, gasoline, some mothproofing substances, etc., or in areas where flammable dust is present.
24. Do not operate the cleaner or any tool while under the influence of drugs or alcohol.
25. **Wear appropriate protective equipment** such as a mask depending on the usage environment.
26. This machine is not intended for use by persons including children with reduced physical, sensory or mental capabilities, or lack of experience and knowledge.
27. Children should be supervised to ensure that they do not play with the cleaner.
28. **Never handle battery(ies) and cleaner with wet hands.**
29. Use extreme caution when cleaning on stairs.
30. Do not use the cleaner on unstable or tilted locations to avoid it falling off resulting in injury or damage.
31. **Keep proper footing and balance at all times.**
32. Do not use the cleaner as a stool or work bench. The machine may fall down and may result in personal injury.
33. **Keep all parts of your body and clothing away from the openings and moving part like the rotating brushroll.** Otherwise they may be caught in the appliance and cause injury.

Battery tool use and care

1. **Recharge only with the charger specified by the manufacturer.** A charger that is suitable for one type of battery pack may create a risk of fire when used with another battery pack.
2. **Use power tools only with specifically designated battery packs.** Use of any other battery packs may create a risk of injury and fire.
3. **When battery pack is not in use, keep it away from other metal objects, like paper clips, coins, keys, nails, screws or other small metal objects, that can make a connection from one terminal to another.** Shorting the battery terminals together may cause burns or a fire.
4. **Under abusive conditions, liquid may be ejected from the battery; avoid contact.** If contact accidentally occurs, flush with water. If liquid contacts eyes, additionally seek medical help. Liquid ejected from the battery may cause irritation or burns.
5. **Do not use a battery pack or tool that is damaged or modified.** Damaged or modified batteries may exhibit unpredictable behaviour resulting in fire, explosion or risk of injury.
6. **Do not expose a battery pack or tool to fire or excessive temperature.** Exposure to fire or temperature above 130 °C may cause explosion.

7. Follow all charging instructions and do not charge the battery pack or tool outside the temperature range specified in the instructions. Charging improperly or at temperatures outside the specified range may damage the battery and increase the risk of fire.

SAVE THESE INSTRUCTIONS.

⚠WARNING: DO NOT let comfort or familiarity with product (gained from repeated use) replace strict adherence to safety rules for the subject product. MISUSE or failure to follow the safety rules stated in this instruction manual may cause serious personal injury.

Important safety instructions for battery cartridge

1. Before using battery cartridge, read all instructions and cautionary markings on (1) battery charger, (2) battery, and (3) product using battery.
2. Do not disassemble or tamper with the battery cartridge. It may result in a fire, excessive heat, or explosion.
3. If operating time has become excessively shorter, stop operating immediately. It may result in a risk of overheating, possible burns and even an explosion.
4. If electrolyte gets into your eyes, rinse them out with clear water and seek medical attention right away. It may result in loss of your eyesight.
5. Do not short the battery cartridge:
 - (1) Do not touch the terminals with any conductive material.
 - (2) Avoid storing battery cartridge in a container with other metal objects such as nails, coins, etc.
 - (3) Do not expose battery cartridge to water or rain.

A battery short can cause a large current flow, overheating, possible burns and even a breakdown.
6. Do not store and use the tool and battery cartridge in locations where the temperature may reach or exceed 50 °C (122 °F).
7. Do not incinerate the battery cartridge even if it is severely damaged or is completely worn out. The battery cartridge can explode in a fire.
8. Do not nail, cut, crush, throw, drop the battery cartridge, or hit against a hard object to the battery cartridge. Such conduct may result in a fire, excessive heat, or explosion.
9. Do not use a damaged battery.
10. The contained lithium-ion batteries are subject to the Dangerous Goods Legislation requirements. For commercial transports e.g. by third parties, forwarding agents, special requirement on packaging and labeling must be observed. For preparation of the item being shipped, consulting an expert for hazardous material is required. Please also observe possibly more detailed national regulations. Tape or mask off open contacts and pack up the battery in such a manner that it cannot move around in the packaging.

11. When disposing the battery cartridge, remove it from the tool and dispose of it in a safe place. Follow your local regulations relating to disposal of battery.
12. Use the batteries only with the products specified by Makita. Installing the batteries to non-compliant products may result in a fire, excessive heat, explosion, or leak of electrolyte.
13. If the tool is not used for a long period of time, the battery must be removed from the tool.
14. During and after use, the battery cartridge may take on heat which can cause burns or low temperature burns. Pay attention to the handling of hot battery cartridges.
15. Do not touch the terminal of the tool immediately after use as it may get hot enough to cause burns.
16. Do not allow chips, dust, or soil stuck into the terminals, holes, and grooves of the battery cartridge. It may cause heating, catching fire, burst and malfunction of the tool or battery cartridge, resulting in burns or personal injury.
17. Unless the tool supports the use near high-voltage electrical power lines, do not use the battery cartridge near high-voltage electrical power lines. It may result in a malfunction or breakdown of the tool or battery cartridge.
18. Keep the battery away from children.

SAVE THESE INSTRUCTIONS.

⚠CAUTION: Only use genuine Makita batteries. Use of non-genuine Makita batteries, or batteries that have been altered, may result in the battery bursting causing fires, personal injury and damage. It will also void the Makita warranty for the Makita tool and charger.

Tips for maintaining maximum battery life

1. Charge the battery cartridge before completely discharged. Always stop tool operation and charge the battery cartridge when you notice less tool power.
2. Never recharge a fully charged battery cartridge. Overcharging shortens the battery service life.
3. Charge the battery cartridge with room temperature at 10 °C - 40 °C (50 °F - 104 °F). Let a hot battery cartridge cool down before charging it.
4. When not using the battery cartridge, remove it from the tool or the charger.
5. Charge the battery cartridge if you do not use it for a long period (more than six months).

PARTS DESCRIPTION

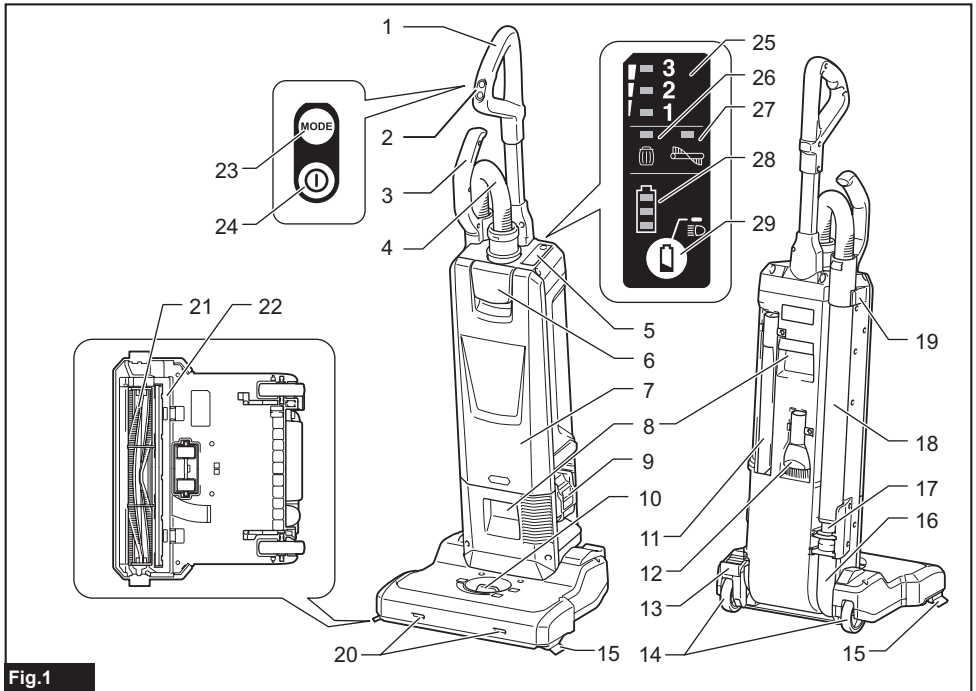

Fig.1

1	Handle	2	Switch plate	3	Pipe grip	4	Hose
5	Indication panel	6	Lever (for the dust box cover)	7	Dust box cover	8	Carrying handle
9	Battery cartridge	10	Adjusting lever	11	Corner nozzle	12	Round brush
13	Foot lever	14	Caster wheel	15	Side brush	16	Suction hose
17	Joint	18	Aluminum pipe	19	Pipe holder	20	Lamp
21	Brushroll	22	Bottom plate	23	Mode change button	24	ON / OFF button
25	Indicator of operating mode	26	Indicator of excess level of dust	27	Indicator of brushroll error	28	Indicator for remaining battery capacity
29	Battery check / lamp button	-	-	-	-	-	-

ASSEMBLY

CAUTION: Always be sure that the appliance is switched off and the battery cartridge is removed before carrying out any work on the appliance.

CAUTION: Always wear dust mask during assembly or maintenance.

Handle connecting

1. Insert the handle pole fully to the cleaner body as shown in the figure.
2. Close the lock latch.

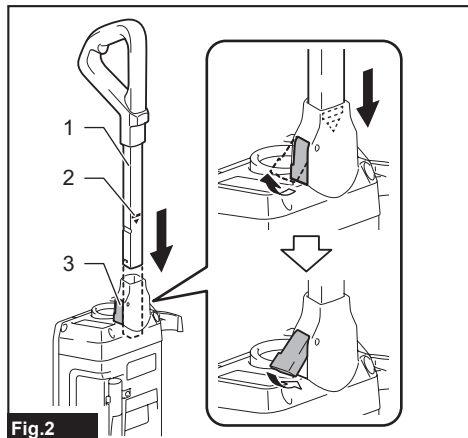

Fig.2

- 1. Handle pole 2. Red marking 3. Lock latch

NOTICE: Insert the handle fully until the red marking cannot be seen.

Hose connecting

Insert the hose into the mounting port of the appliance and turn the hose until it locks.

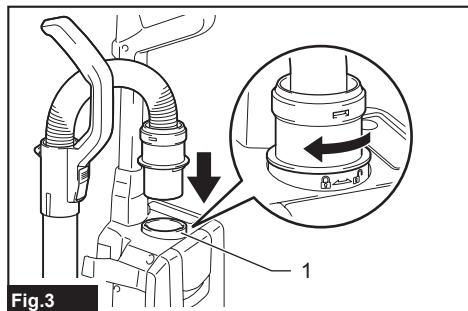

Fig.3

- 1. Mounting port

Pipe connecting

Insert the tip of the aluminum pipe to the joint, and then attach the aluminum pipe to the pipe holder.

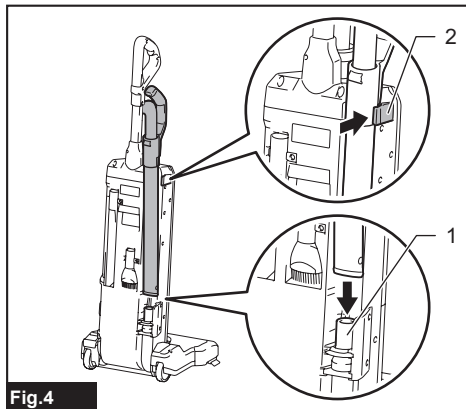

Fig.4

- 1. Joint 2. Pipe holder

NOTICE: Insert the aluminum pipe in correct direction as shown in figure. Otherwise the pipe holder will not be locked and the aluminum pipe may come off.

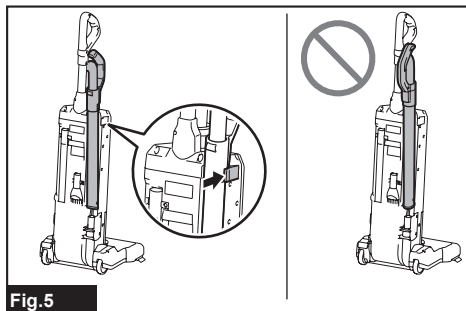

Fig.5

Installing or removing battery cartridge

CAUTION: Always switch off the appliance before installing or removing the battery cartridge.

CAUTION: Hold the cleaner and the battery cartridge firmly when installing or removing the battery cartridge. Failure to hold the cleaner and the battery cartridge firmly may cause them to slip off your hands and result in damage to the cleaner and battery cartridge and a personal injury.

CAUTION: Be careful not to pinch your fingers when installing the battery cartridge. Failure to do so may cause personal injury.

CAUTION: Do not install/remove the battery cartridge with wet hands. There is a risk of electric shock.

Align the tongue on the battery cartridge with the groove in the housing and slip it into place. Insert it all the way until it locks in place with a little click.

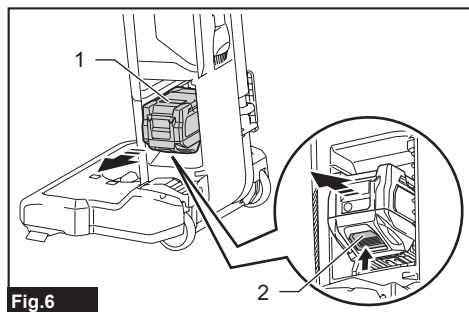

Fig.6

► 1. Battery cartridge 2. Button

To remove the battery cartridge, take it out from the appliance while sliding up the button in front of the cartridge.

CAUTION: Always install the battery cartridge fully. If not, it may accidentally fall out of the appliance, causing injury to you or someone around you.

CAUTION: Do not install the battery cartridge forcibly. If the cartridge does not slide in easily, it is not being inserted correctly.

Installing the filter bag

CAUTION: Do not use a damaged filter bag. Always use the vacuum cleaner with the filter bag properly installed. Otherwise the vacuumed dust or particles may be exhausted from the cleaner and they may cause respiratory disease to the operator.

Install the filter bag before using cleaner. Filter bag is a throw-away type. Throw away the entire filter bag without emptying when it has become full.

NOTICE: When the filter bag is already full or clogged, replace with new one. Continuous use with the filter bag full or clogged results in reduced suction power.

NOTICE: To prevent dust from getting into the motor:

- Make sure that the filter bag is installed before use.
- Do not use a broken or ripped bag.

Otherwise the motor may be broken.

NOTICE: Do not fold the cardboard at its opening when installing the filter bag.

NOTICE: The filter bag for the cleaner is an important component for maintaining the appliance performance. Using non-genuine filter bag may cause smoke or ignition.

NOTE: When the filter bag is not installed in the appliance, the dust box cover does not close completely.

NOTE: A reusable dust bag is preinstalled in some countries and regions. You can follow the same installation/uninstallation steps as for the filter bag.

1. Unlock the lever and open the dust box cover.

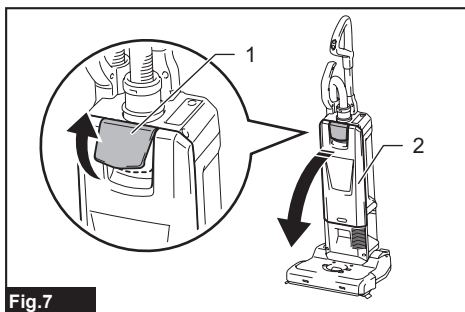

Fig.7

- 1. Lever 2. Dust box cover

2. Unfold the filter bag fully.

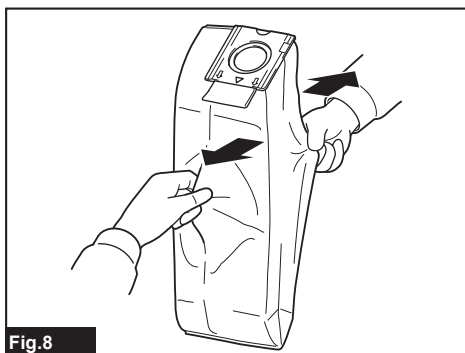

Fig.8

3. Open the latch and insert the filter bag into the slot on the holder so that the side with the Δ mark enters first.

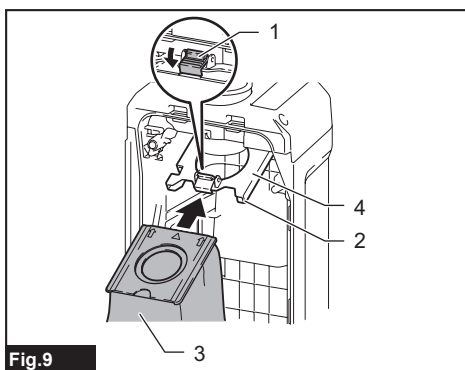

Fig.9

- 1. Latch 2. Slot 3. Filter bag 4. Holder

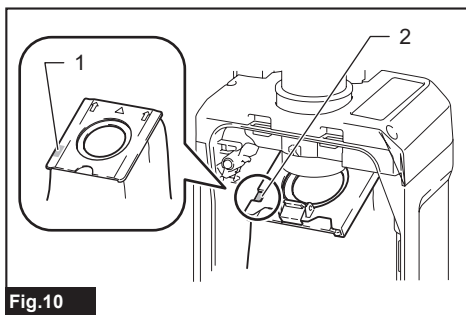

Fig.10

- ▶ 1. Marking 2. Slit

NOTE: Make sure that only the marking on the cardboard can be seen through the slit of the holder.

- 4. Hook the latch of the holder.

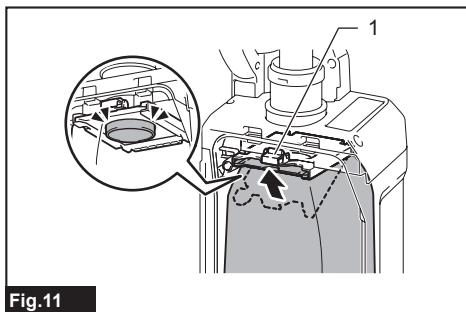

Fig.11

- ▶ 1. Latch

- 5. Unfold the filter bag if it is folded.

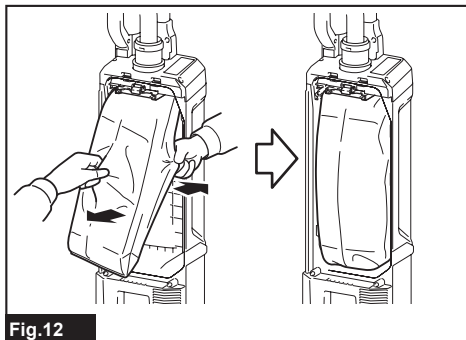

Fig.12

- 6. Lock the dust box cover securely.

CAUTION: Be careful not to pinch your fingers when hooking the latch, and when closing the dust box cover.

Removing the filter bag

CAUTION: Handle the filter bag softly. Otherwise foreign objects are blown into eyes, it may result in personal injury.

Replace the filter bag when it becomes full or clogged. Open the dust box cover and open the latch, then take out the filter bag.

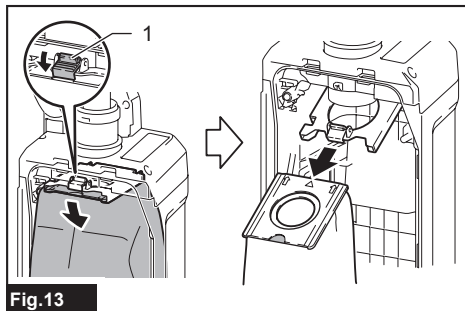

Fig.13

- ▶ 1. Latch

Pull the strip on the side of the opening to shut the filter bag and dispose of the entire filter bag.

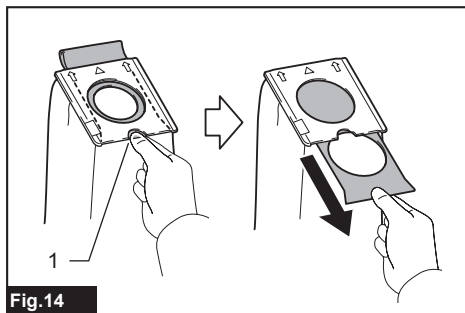

Fig.14

- ▶ 1. Strip

NOTICE: Do not reuse a filter bag. The filter bag is designed for single-use purposes. Using a filter bag repeatedly may cause clogging of the filter and result in damage to the appliance.

FUNCTIONAL DESCRIPTION

CAUTION: Always be sure that the appliance is switched off and the battery cartridge is removed before adjusting or checking function on the appliance.

Appliance / battery protection system

The appliance is equipped with an appliance/battery protection system. This system automatically cuts off power to the motor to extend appliance and battery life. The appliance will automatically stop during operation if the appliance or battery is placed under one of the following conditions:

Overload protection

When the appliance is operated in a manner that causes it to draw an abnormally high current, the appliance automatically stops. In this situation, turn the appliance off and stop the application that caused the appliance to become overloaded. Then turn the appliance on to restart.

Overheat protection

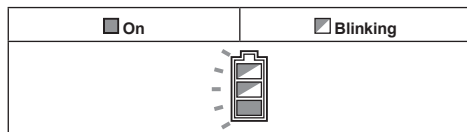

When the appliance is overheated, the appliance stops automatically, and the battery indicator blinks about 60 seconds. In this situation, let the appliance cool down before turning the appliance on again.

Overdischarge protection

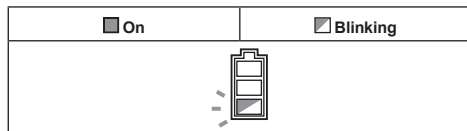

When the battery capacity becomes low, the appliance stops automatically, and the battery indicator blinks about 60 seconds. If the product does not operate even when the switches are operated, remove the battery from the appliance and charge the battery.

Indicating the remaining battery capacity

Press the check button on the battery cartridge to indicate the remaining battery capacity. The indicator lamps light up for a few seconds.

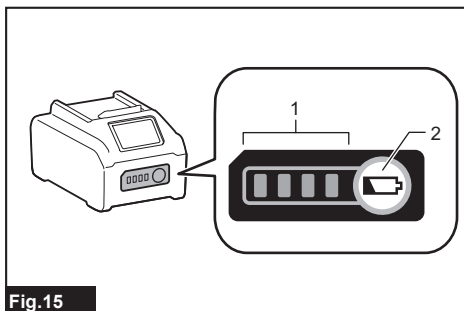

Fig.15

► 1. Indicator lamps 2. Check button

Indicator lamps			Remaining capacity
Lighted	Off	Blinking	
			75% to 100%
			50% to 75%
			25% to 50%
			0% to 25%
			Charge the battery.
			The battery may have malfunctioned.

NOTE: Depending on the conditions of use and the ambient temperature, the indication may differ slightly from the actual capacity.

NOTE: The first (far left) indicator lamp will blink when the battery protection system works.

Indication panel

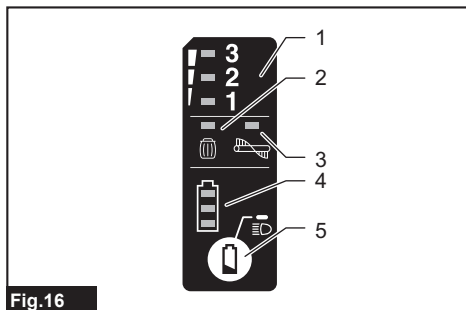

Fig.16

- ▶ 1. Operating mode 2. Excess level of dust
- 3. Brushroll error 4. Remaining battery capacity
- 5. Battery check / lamp button

Operating mode

To change the operating mode, refer to the section for switch action.

Excess level of dust

If this indicator lights up, replace the filter bag. (Refer the section on removing the filter bag.)

NOTE: This indicator may not work depending on the usage environment.

NOTE: The indicator automatically goes out approximately one minute after the appliance is switched off. If you clear the clogging of the filter bag and restart the appliance, the indicator goes out even within one minute.

Brushroll error

Blinking	The brushroll is under high load for some reasons.
On	The brushroll is stopped by abnormal reason.

⚠WARNING: Immediately switch off the appliance when this lamp lights up during operation. Otherwise the motor malfunction may occur and a fire may be caused.

NOTE: The lamp may blink if the height of the brushroll is too low against the surface of the carpet. In that case, adjust the height of the brushroll.

Remaining battery capacity

During operation, press the battery check / lamp button to indicate the remaining battery capacity.

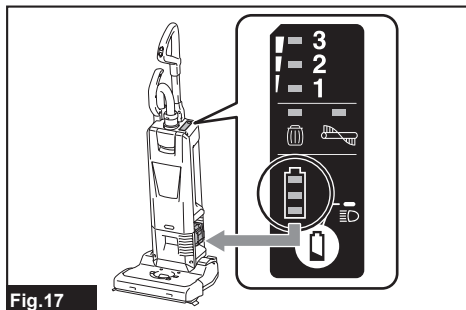

Fig.17

Battery indicator status			Remaining battery capacity
On	Off	Blinking	
			50% to 100%
			20% to 50%
			0% to 20%
			Charge the battery

Battery check / lamp button

The following operations can be performed.

- Simply press the button to check the remaining battery capacity.
- During operation, press and hold the button to turn on / off the lamps.

Switch action

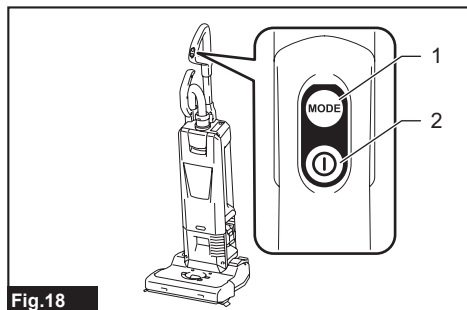

Fig.18

► 1. Mode change button 2. ON / OFF button

Turning the appliance on / off

Press the ON / OFF button to turn the appliance on and off.

CAUTION: Always put the head of the appliance on the floor when turning on the appliance. Otherwise an accident due to entanglement may occur and cause a personal injury.

Changing operating mode

There are the following three operating modes:

1. Low noise level
2. Normal
3. High

To change the operating mode, press the mode change button. The operating mode can be changed even when the appliance is turned off. The appliance will start in the mode you set.

NOTE: The cleaner starts in the same mode as the last operation. If you remove the battery while the motor is running after the shutdown, the cleaner may not start in the same mode as the last operation.

Turning lamp on / off

CAUTION: Do not look in the light or see the source of light directly.

The appliance is equipped with the lamps. See the paragraph of the battery check / lamp button for operation.

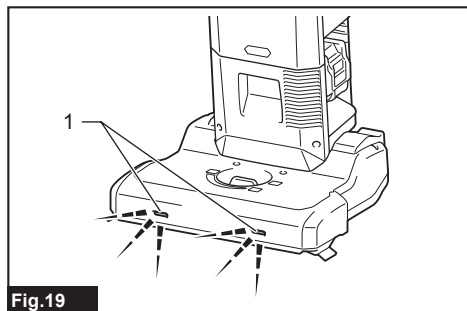

Fig.19

► 1. Lamp

Foot lever

CAUTION: Always lock the appliance in upright position when you let go of the handle. Otherwise the appliance may accidentally fall and cause injury.

CAUTION: Be careful not to pinch your fingers between the main body and the head of the appliance.

To unlock the upright position of the appliance, step on the foot lever and pull the handle backward. The range of motion is 90 degrees from the upright position.

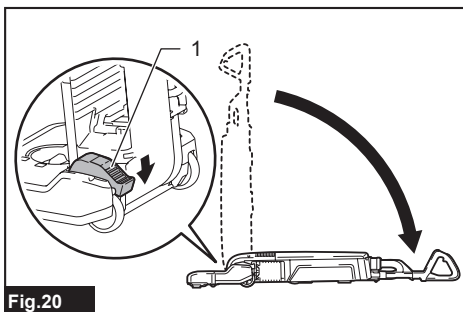

Fig.20

► 1. Foot lever

To lock the appliance in upright position, raise up the handle forward until the foot lever locks the position with click.

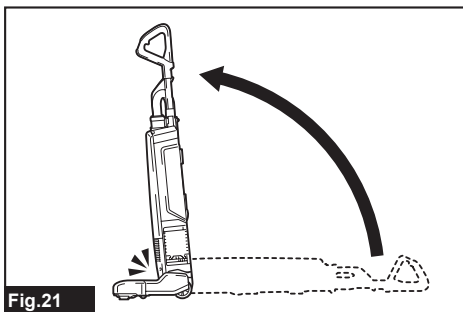

Fig.21

CAUTION: Be sure to unlock the foot lever before operating. Rough handling may cause breakage of the parts.

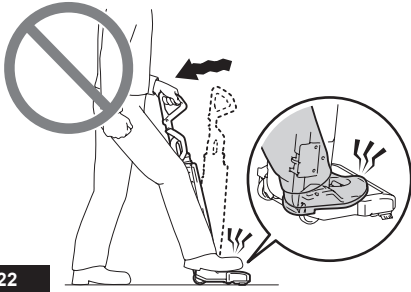
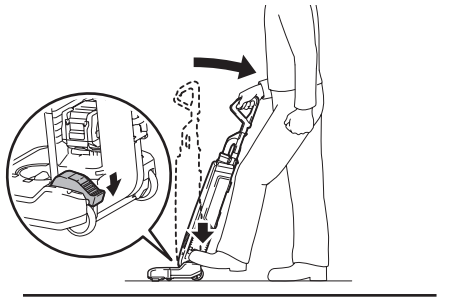

Fig.22

NOTE: While the appliance is in the upright position, the brushroll stops rotating.

Adjusting the height of the brushroll

CAUTION: Always make sure that the adjusting lever comes into the position properly before operation.

The height of the brushroll can be adjusted in 5 steps. Turn the adjusting lever to your desired position by referring to the following table.

Adjusting lever position	Brushroll height
A (☰)	The brushroll stays positioned to the top from the floor, which is suitable for cleaning long-haired carpets.
B (☲)	The brushroll is positioned lower to the floor, which is suitable for cleaning hard floors and short-haired carpets.
C (☱)	The brushroll extends down to the floor, which is effective for deep cleaning carpets and removing dirt, dust and particles embedded deep in the fibers.

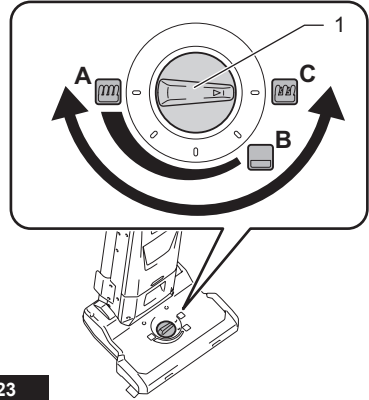

Fig.23

► 1. Adjusting lever

NOTE: The brushroll may not rotate if the height of the brushroll is too low against the surface of the carpet.

Carrying handle

When carrying the appliance, push the appliance with the caster wheels only, or carry it by holding the carrying handle(s).

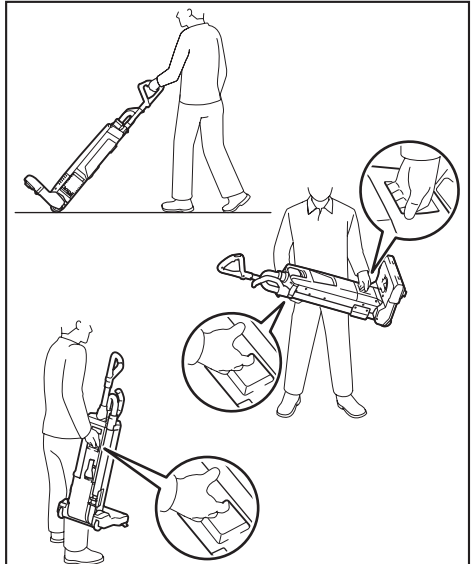

Fig.24

CAUTION: When carrying the appliance, lock the appliance in upright position. Otherwise falling accident may occur.

CAUTION: Do not carry the appliance with anything other than the carrying handle. Otherwise falling accident may occur or unintentional starting may cause an injury.

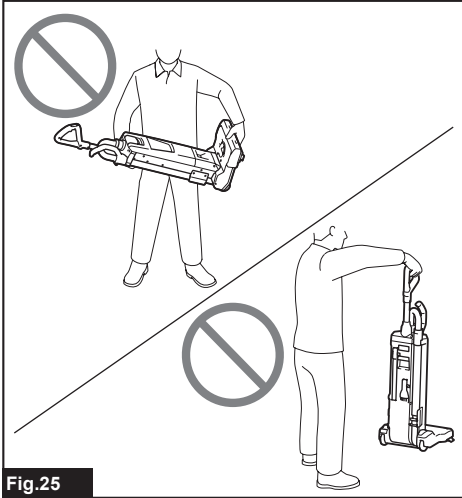

Fig.25

OPERATION

CAUTION: Do not pull out the handle pole from the appliance during operation. Doing so lose control of the appliance and may result serious injury.

CAUTION: Do not put your hand or leg under the appliance during operation. Otherwise pinching accident may occur.

CAUTION: Do not use the appliance in insufficient lighting. Working in poor light may contribute to an unforeseen accident.

Normal cleaning operation

1. Hold the handle, and then unlock the upright position.
2. Turn on the appliance. Clean a floor.



Fig.26

Using the side brush

The side brush is convenient for cleaning the corner of a wall.

If the side brush gets short, take the appliance to the Makita service center for replacement.

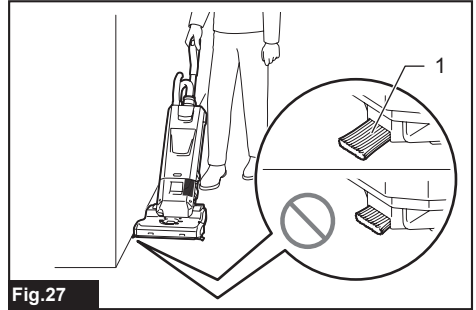

Fig.27

► 1. Side brush

Operation with accessories

CAUTION: Keep holding the handle when using accessories. Otherwise the appliance may accidentally fall and cause injury.

NOTICE: When using accessories, lock the appliance in upright position. Otherwise the rotation of the brushroll may damage the floor.

Using the aluminum pipe

The aluminum pipe is suitable for cleaning tight quarters, or high places.

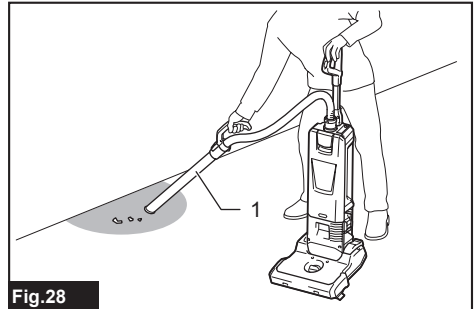

Fig.28

► 1. Aluminum pipe

Using the hose

The hose is suitable for cleaning near your hands.

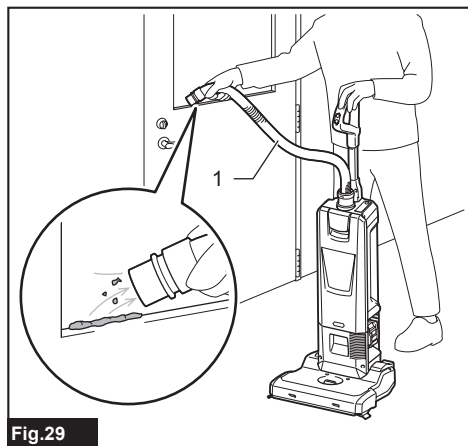

Fig.29

► 1. Hose

To use the hose, pull out the hose from the aluminum pipe while pushing the lever.

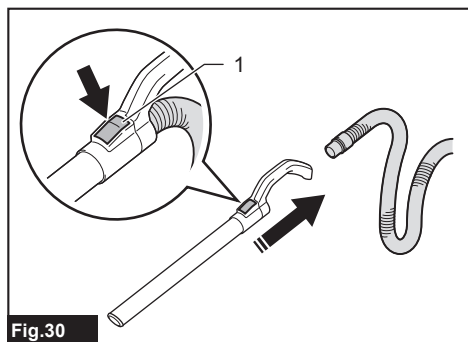

Fig.30

► 1. Lever

To install the hose, insert the hose into the aluminum pipe until it clicks.

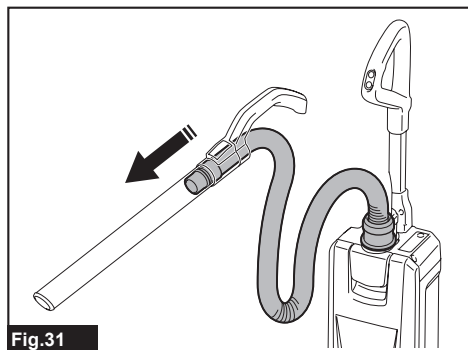

Fig.31

Using the attachments

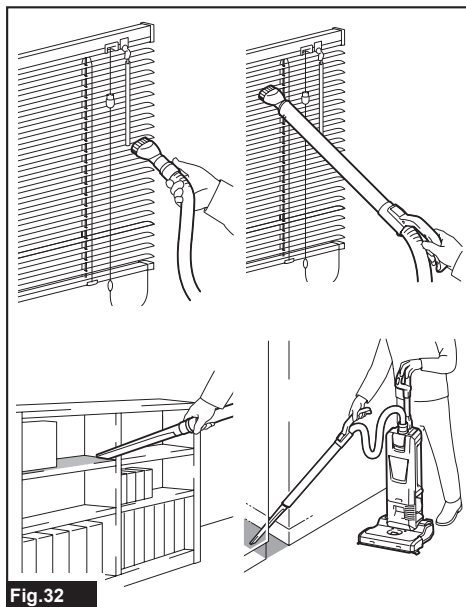

Fig.32

To install the attachment, twist and insert it securely to the aluminum pipe or the hose. To disconnect, twist and remove it.

MAINTENANCE

CAUTION: Always be sure that the appliance is switched off and the battery cartridge is removed before attempting to perform inspection or maintenance.

NOTICE: Never use gasoline, benzine, thinner, alcohol or the like. Discoloration, deformation or cracks may result.

To maintain product SAFETY and RELIABILITY, repairs, any other maintenance or adjustment should be performed by Makita Authorized or Factory Service Centers, always using Makita replacement parts.

Storage

When storing, remove the battery cartridge and store the appliance on level place in upright position.

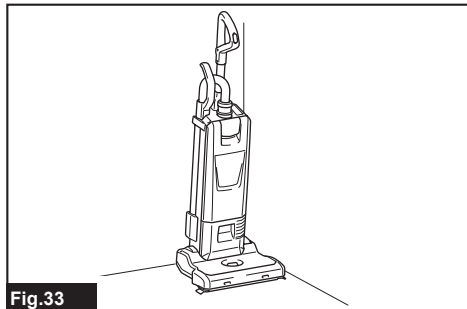

Fig.33

Cleaning the appliance body

From time to time wipe off the outside of the cleaner (cleaner body) using a cloth dampened in soapy water.

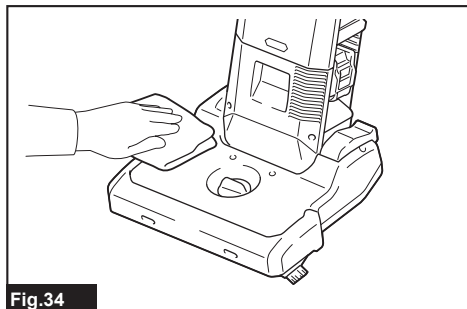

Fig.34

Cleaning the HEPA filter

CAUTION: Do not use the cleaner without a filter or continue to use dirty or damaged filter. Vacuumed dust or particles may be exhausted from the cleaner and they may cause respiratory disease to the operator.

NOTICE: To keep optimum suction power and clean exhaust, clean the filter periodically. If enough suction power is not obtained even after the cleaning, replace the filter with new one.

NOTICE: To prevent the filter from being damaged, do not use following tools and similar items for cleaning:

- Air duster
- High pressure washer
- Tools made of hard materials such as a wire brush

1. Open the dust box cover and take out the filter bag.

Release the hooks on the filter and remove the filter from the appliance body.

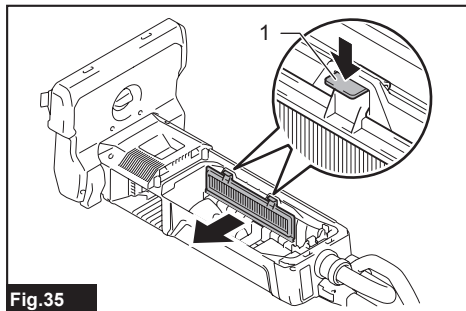

Fig.35

- 1. Hook

2. Beat the dust off from the filter. The filter can be washed with water. Rinse away the dust and particles on the filter every 1 or 2 months. After that, dry the filter completely in a shaded and well-ventilated place to prevent unpleasant odor or malfunctions.

3. To install the filter, insert the side without the hooks into the groove, then push in the filter until the hooks are secured with a click.

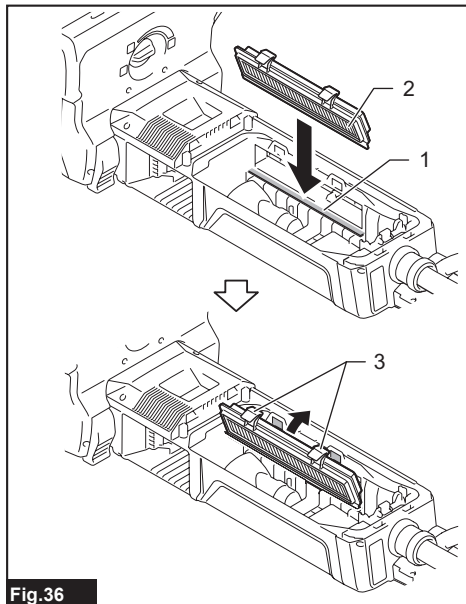

Fig.36

- 1. Groove 2. HEPA filter 3. Hook

Cleaning the brushroll

1. Remove the bottom plate, and then remove the brushroll.

If the hair of the brushroll gets short, ask the Makita service center for new one.

Operating the appliance with the short hair brushroll results in poor dust collecting.

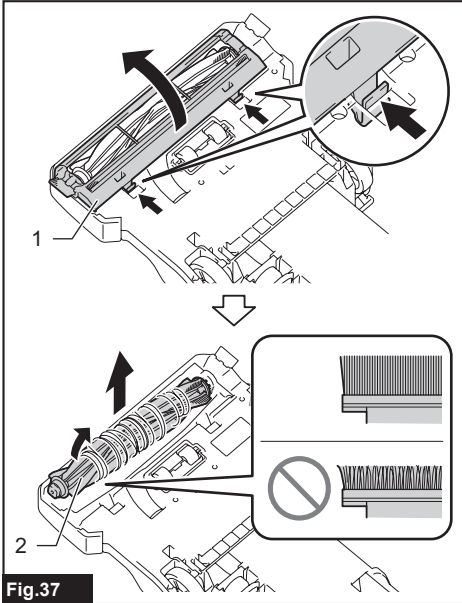

Fig.37

- 1. Bottom plate 2. Brushroll

2. Remove threads and hairs from the brushroll using scissors.

Remove the cap and clean debris.

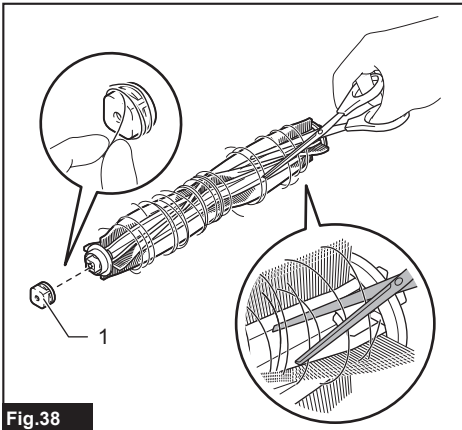

Fig.38

- 1. Cap

3. Install the cap, brushroll, and bottom plate in reverse order.

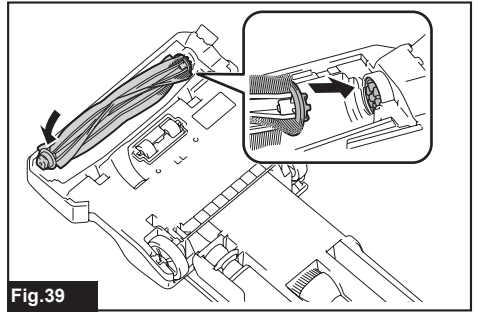

Fig.39

CAUTION: Place the bottom plate back in the position securely until the two lock levers click in place. If the appliance is operated without the bottom plate, the brushroll may come off, resulting in injury.

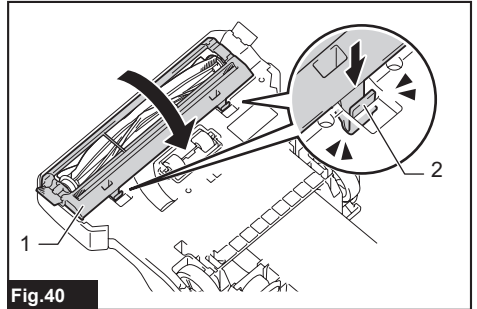

Fig.40

- 1. Bottom plate 2. Lock lever

NOTICE: Always attach the brushroll. Operating the appliance without the brushroll results in poor dust collecting.

How to clear the clog

NOTICE: Do not operate the appliance with the intake flow path clogged. Continuous use with the intake flow path clogged results in reduced suction power.

1. Remove the bottom plate, and then remove the brushroll.
2. Remove the aluminum pipe from the appliance and from the hose.
3. Turn the hose counterclockwise, and then remove the hose from the appliance.
4. Remove the suction hose by pulling the tab.

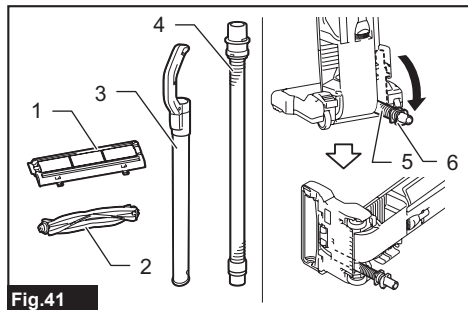

Fig.41

- 1. Bottom plate 2. Brushroll 3. Aluminum pipe
4. Hose 5. Suction hose 6. Tab

5. Inspect the intake flow path of air for the inside of the aluminum pipe and the hose, and the suction hose. Remove the debris from inside of them.
6. Align the tongue of the suction hose with the groove in the housing and slip it into place.

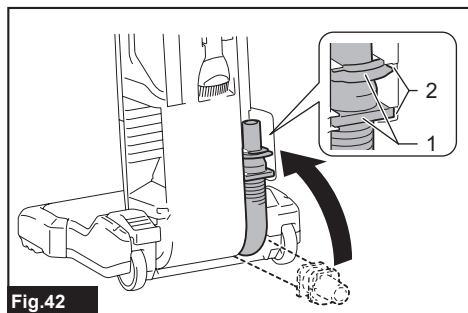

Fig.42

- 1. Tongue 2. Groove

7. Install the hose, aluminum pipe, brushroll, and bottom plate.

CAUTION: Install the hose, pipe firmly. Otherwise dust leakage may occur and cause injury.

Dust bag

Optional accessory

The dust bag can be used repeatedly by cleaning it out.

Installing and removing dust bag

The procedure of installing and removing the dust bag is same as the filter bag. Please refer to the section for installing the filter bag and removing the filter bag.

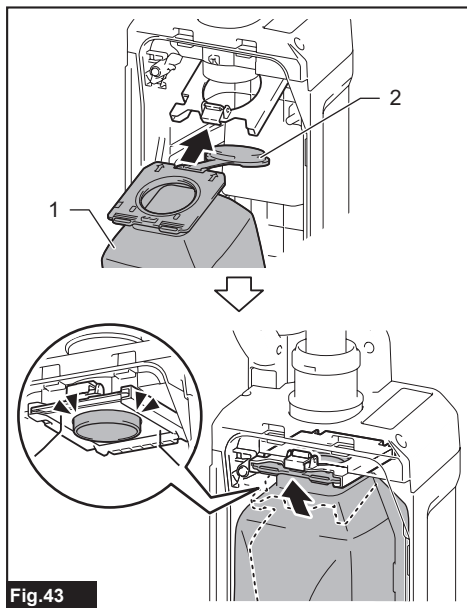

Fig.43

- 1. Dust bag 2. Rubber cap

NOTICE: When installing the dust bag, open the rubber cap first. Insert the dust bag with the rubber cap behind.

Emptying dust bag

1. Close the rubber cap to prevent dust from floating out.
2. Open the bag mouth by pulling the fastener out.
3. Empty the dust bag of its contents, tapping it lightly so as to remove particles adhering to the insides.

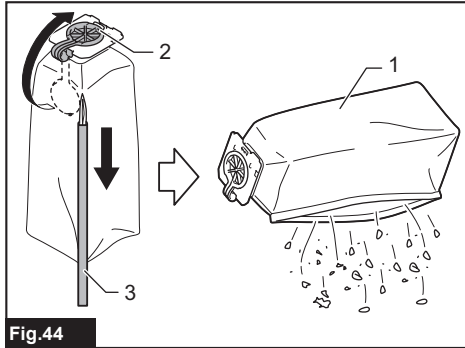

- 1. Dust bag 2. Rubber cap 3. Fastener

NOTICE: Empty the dust bag frequently. Too much dust will tear the bag easily.

Cleaning the dust bag

Regularly clean the dust bag with soap and water. Turn the dust bag inside out and remove the sticky dust. Wash lightly by hand and rinse well with water. Dry completely before installing to the vacuum cleaner.

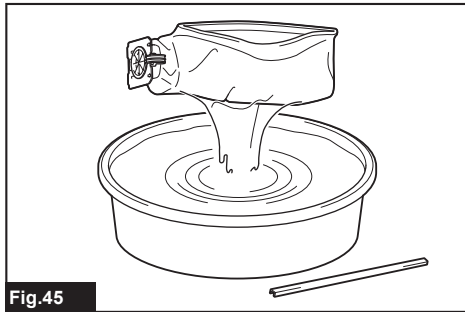

NOTICE: Wet dust bag lowers the vacuuming performance as well as the life of the motor.

NOTICE: When mounting the fastener on the dust bag, make sure that the bag mouth is securely closed.

CYCLONE ATTACHMENT

Optional accessory

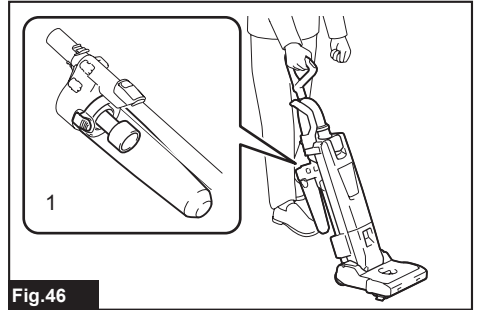

- 1. Cyclone attachment

About the cyclone attachment

Using the cleaner with the cyclone attachment installed reduces the amount of dust that enters the filter bag, which helps to prevent the suction force from weakening. In addition, cleaning after use is also simple.

CAUTION: Always be sure that the tool is switched off and the battery cartridge is removed before carrying out any work on the tool. If the battery cartridge is left inserted, the cleaner may start unexpectedly and result in injury.

CAUTION: Clean the mesh filter of the cyclone attachment and the filter bag of the cleaner unit when they become clogged.

Continued use in the clogged condition may result in heating or smoke.

NOTICE: When the cyclone attachment is attached, do not use the cyclone attachment in the horizontal or upward facing condition. Doing so may cause the mesh filter to become clogged.

NOTICE: Always use the cleaner with the filter bag installed, even when using the cyclone attachment. Using the cleaner without the filter bag installed may result in a motor malfunction.

NOTE: Check that the cyclone attachment, cleaner, and straight pipe are locked properly before use.

NOTE: Empty the dust case of the cyclone attachment and the filter bag of the cleaner when dust has accumulated. Continued use will result in weakened suction force.

Installing cyclone attachment

1. Turn the cuff on the hose counterclockwise and remove the hose, pipe grip, and aluminum pipe from the appliance.

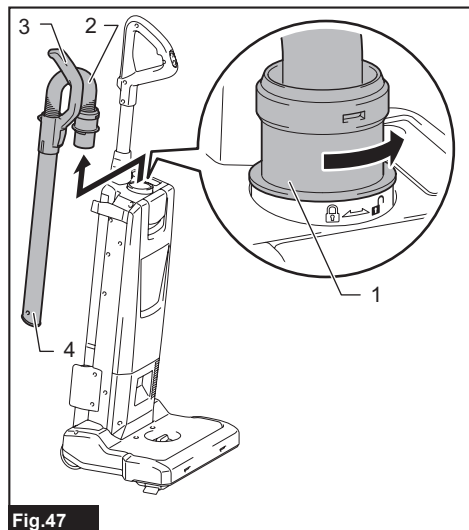

Fig. 47

- 1. Cuff 2. Hose 3. Pipe grip 4. Aluminum pipe

2. Turn the side of the stopper on the cyclone attachment upward, aligning the stopper with the groove of the suction inlet. Lock the stopper by inserting the cyclone attachment until it clicks. Pull the cyclone attachment lightly to make sure it will not be removed. Install the straight pipe with the same procedure as the cyclone attachment.

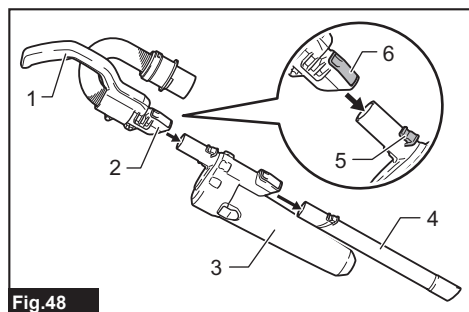

Fig. 48

- 1. Grip for cyclone attachment 2. Suction inlet
3. Cyclone attachment 4. Straight pipe for cyclone attachment 5. Stopper 6. Locking button

3. Install the cyclone attachment on the appliance, and then turn the cuff on the hose clockwise to fix it.

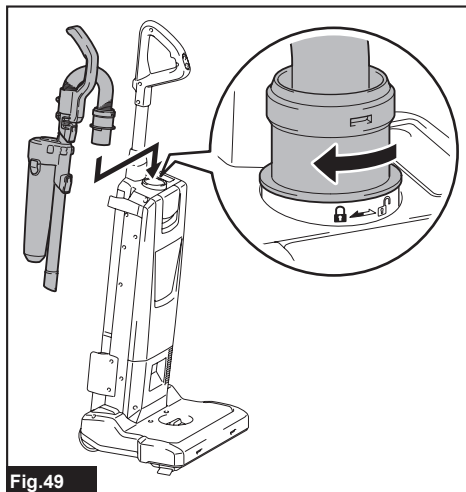

Fig. 49

Disposing of dust

When dust has accumulated up to the full line of the dust case, follow the procedure below and dispose of the dust.

1. Hold the dust case firmly, press and hold the two buttons, and remove the dust case.

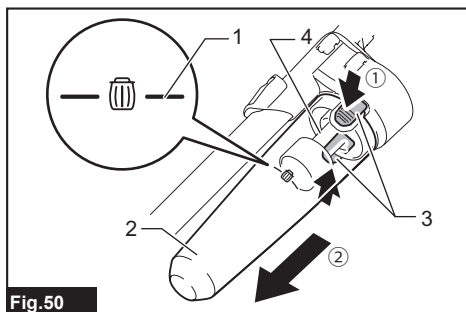

Fig. 50

- 1. Full line 2. Dust case 3. Button (two locations)
4. Mesh filter

2. Dispose of the dust inside the dust case and remove any dust and powder adhered to the surface of the mesh filter.

3. Insert the dust case all the way until the two buttons lock with a click.

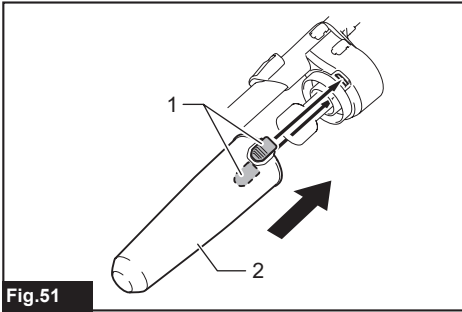

Fig.51

- 1. Dust case 2. Button (two locations)

NOTE: Hold the cyclone attachment firmly when installing the dust case.

NOTE: Check that the cyclone attachment, cleaner, and straight pipe are locked properly before restarting operation.

NOTE: The indicator of excess level of dust on the cleaner will not light up when the dust case of the cyclone attachment becomes full.

NOTE: Under the following conditions, check whether dust has accumulated inside the filter bag of the cleaner or clogging in the air path has occurred. Clear the causes where necessary.

- If the suction performance does not improve after you have removed dust from the dust case and cleaned the mesh filter.
- If the indicator of excess level of dust on the cleaner continues to light up.

Cleaning

When the dust case becomes dirty or the mesh filter is clogged, remove and wash them with water. (Refer to "Disposing of dust" for the removal procedure.)

Dry the parts thoroughly before reinstallation and use.

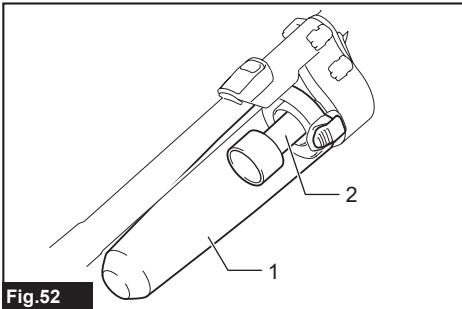

Fig.52

- 1. Dust case 2. Mesh filter

When the mesh filter gets dirty badly, clean it in the following procedures.

1. Turn the mesh filter counterclockwise and remove it while the hooks are unlocked.

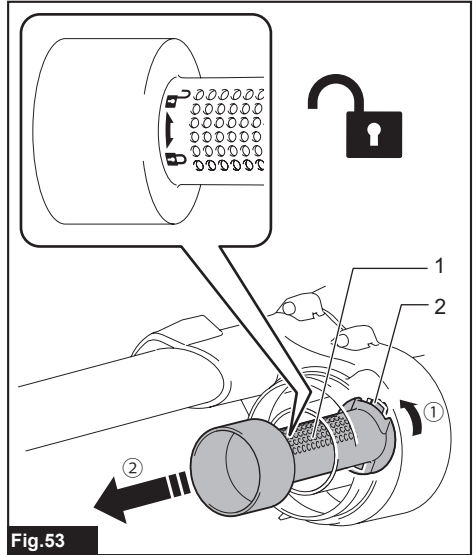

Fig.53

- 1. Mesh filter 2. Hook

2. Remove the dust on the mesh filter and then wash it with water. After that, dry it thoroughly.

3. Insert the mesh filter into the base while the hooks are aligned with the port. Turn the mesh filter clockwise until the hooks are locked with a click. Make sure that the mesh filter is installed securely.

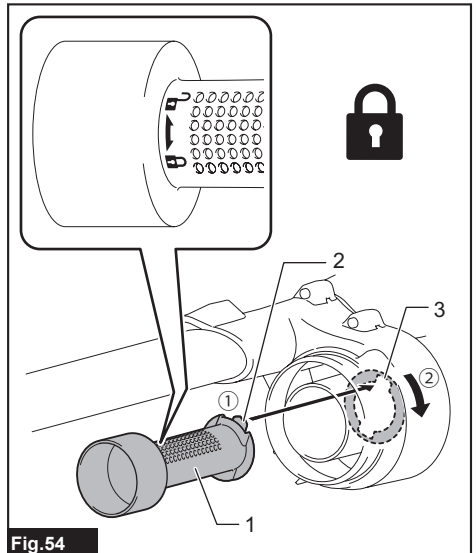

Fig.54

- 1. Mesh filter 2. Hook 3. Port

TROUBLESHOOTING

Before asking for repairs, conduct your own inspection first. If you find a problem that is not explained in the manual, do not attempt to disassemble the machine. Instead, ask Makita Authorized Service Centers, always using Makita replacement parts for repairs.

Symptom	Probable cause	Remedy
Not working	The battery cartridge is installed improperly.	Install the battery cartridge as described in this manual.
	The battery cartridge is exhausted.	Charge the battery cartridge.
	The handle is installed improperly.	Install the handle firmly as described in this manual.
The brushroll does not rotate	The appliance is locked in upright position.	Unlock the upright position of the appliance.
	The indicator of the brushroll error is lighting.	Inspect that there is no entanglement around the brushroll (body, cap and joint).
Weak suction power	The indicator of excess level of dust is lighting.	Replace the filter bag. If the filter bag is not full, unfold the filter bag and shake it to clear the clogging.
	⇒If replacing the filter bag does not solve the problem...	Clean or replace the HEPA filter. Inspect that there is no debris clogged in the hose and pipe.
	Debris is entangled in the brushroll and the rotating speed is declined.	Inspect that there is no entanglement around the brushroll (body, cap, joint).
	The height of the brushroll is too high from the floor.	Lower the height of the brushroll.
	The hair of the brushroll has become short.	Replace the brushroll. Lower the height of the brushroll.
	The appliance is operating in low mode.	Change to the higher operating mode.
	The brushroll is not installed.	Install the brushroll.
	The pipe or the hose is installed improperly.	Install the pipe or the hose firmly.
Loud driving noise	The appliance is operating in high mode.	Change to the lower operating mode.
	Debris is entangled in the brushroll.	Inspect that there is no entanglement around the brushroll (body, cap and joint).
	The filter bag is filled with dust.	Replace the filter bag.
	⇒If replacing the filter bag does not solve the problem...	Clean or replace the HEPA filter. Inspect that there is no debris clogged in the hose and pipe.
The indicator of excess level of dust blinks after a little use	The filter bag is folded.	Unfold the entrance of the filter bag before setting it.
Lamp does not light	The lamp setting is off.	During operation, press and hold the battery check / lamp button to turn on the lamp.
The caster wheel is hard to move	Debris is entangled in the caster wheel.	Clean the debris on the caster wheel.

OPTIONAL ACCESSORIES

⚠ CAUTION: These accessories or attachments are recommended for use with your Makita tool specified in this manual. The use of any other accessories or attachments might present a risk of injury to persons. Only use accessory or attachment for its stated purpose.

If you need any assistance for more details regarding these accessories, ask your local Makita Service Center.

- Corner nozzle
- Round brush
- Cyclone attachment
- HEPA filter
- Filter bag
- Dust bag
- Makita genuine battery and charger

NOTE: Some items in the list may be included in the tool package as standard accessories. They may differ from country to country.

Makita Europe N.V.

Jan-Baptist Vinkstraat 2, 3070 Kortenberg, Belgium

Makita Corporation

3-11-8, Sumiyoshi-cho, Anjo, Aichi 446-8502 Japan

www.makita.com



885A55-226
EN
20230913